

NTN for IoT : How to?

Fabien Ferrero,
LEAT, Université Côte d'Azur



Communication non-terrestre pour l'IoT : quelles sont les solutions

Introduction

- Space from IoT
- Applications

LEO

- LEO with Lacuna
- Circular polarization
- Experiments
- Relay mode

MEO/GEO

- ICO-F2
- ECHO XXI
- Echostar
- Terminal
- Test

Conclusions

Motivation

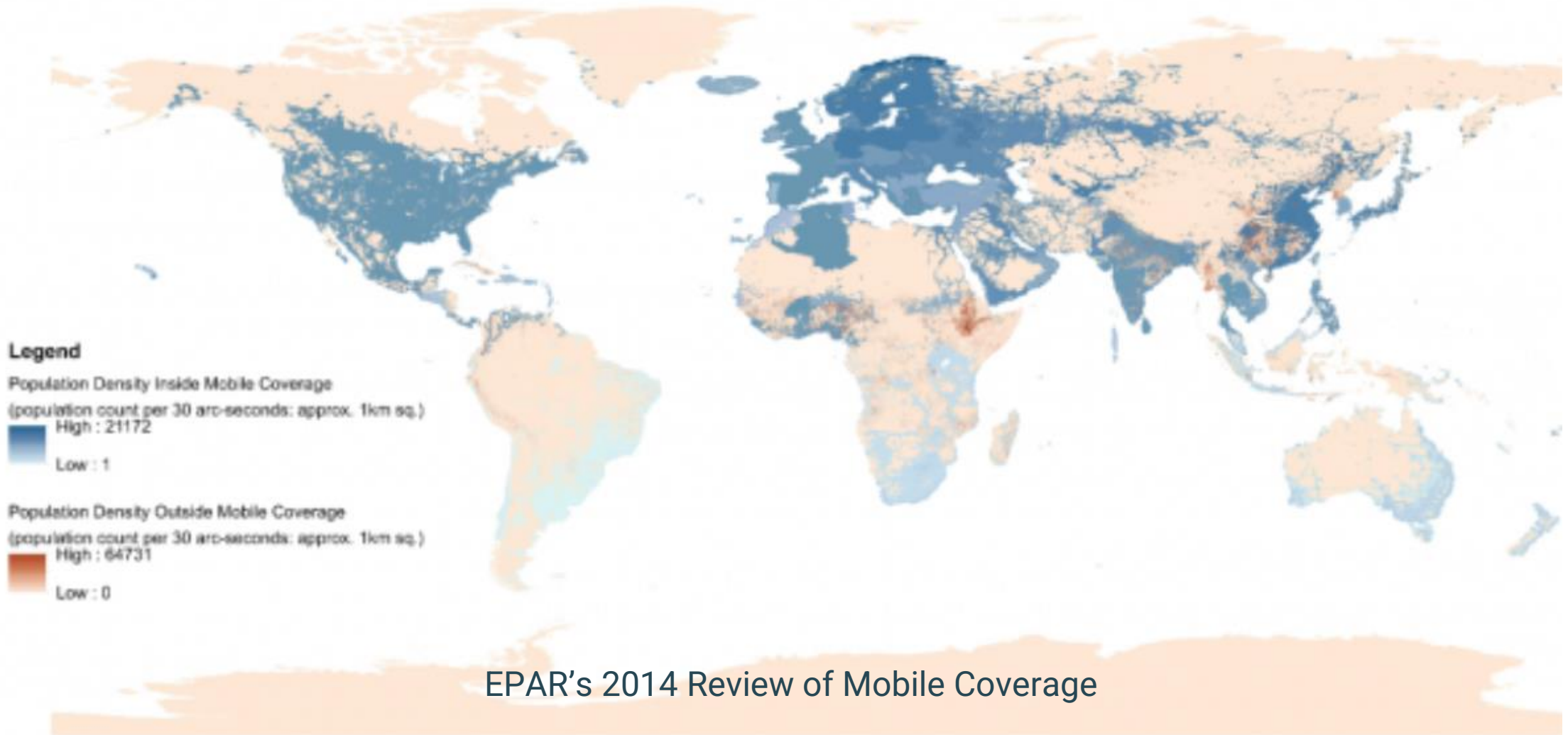

EPAR's 2014 Review of Mobile Coverage

Applications : Volcano monitoring

- RAVIOLI (*Radon Analysis on Volcanoes with In-situ Observations of short-Lived Isotopes*)
- Radon gaz sensor @ Etna, Masaya, Soufrière volcanos
- Can be used to predict volcanic activity
- Sensor are moved depending on volcano activity
- A terrestrial LoRaWan network has been deployed, but the coverage is limited

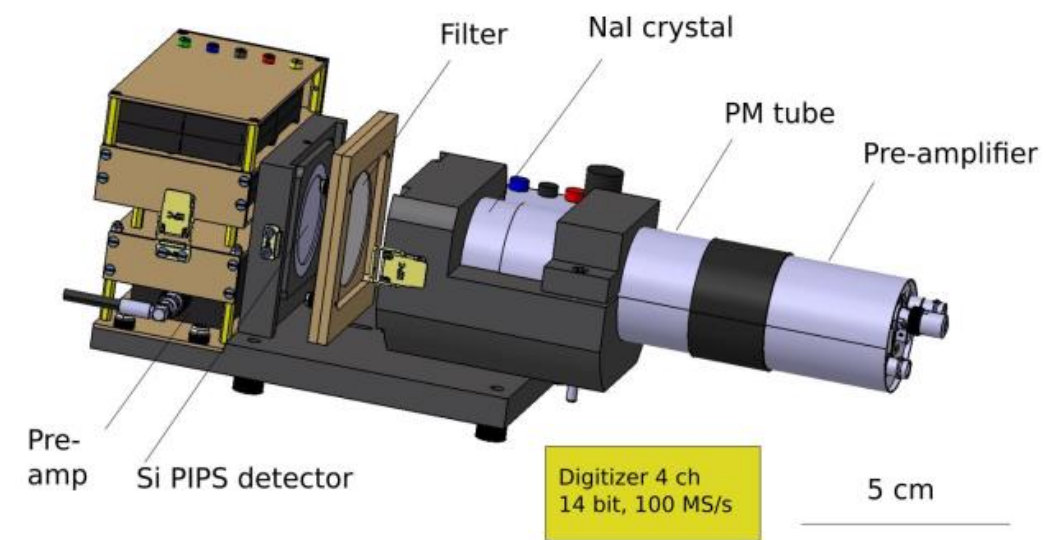

Application : Wildlife monitoring

- Based on low-power camera with AI classification (Mobicet on TF Lite Micro)
- Wake-up based on PIR
- Species classes counters sent periodically thru a LoRaWAN private network
- Sites
 - Alps valleys(not covered by public IoT operators)

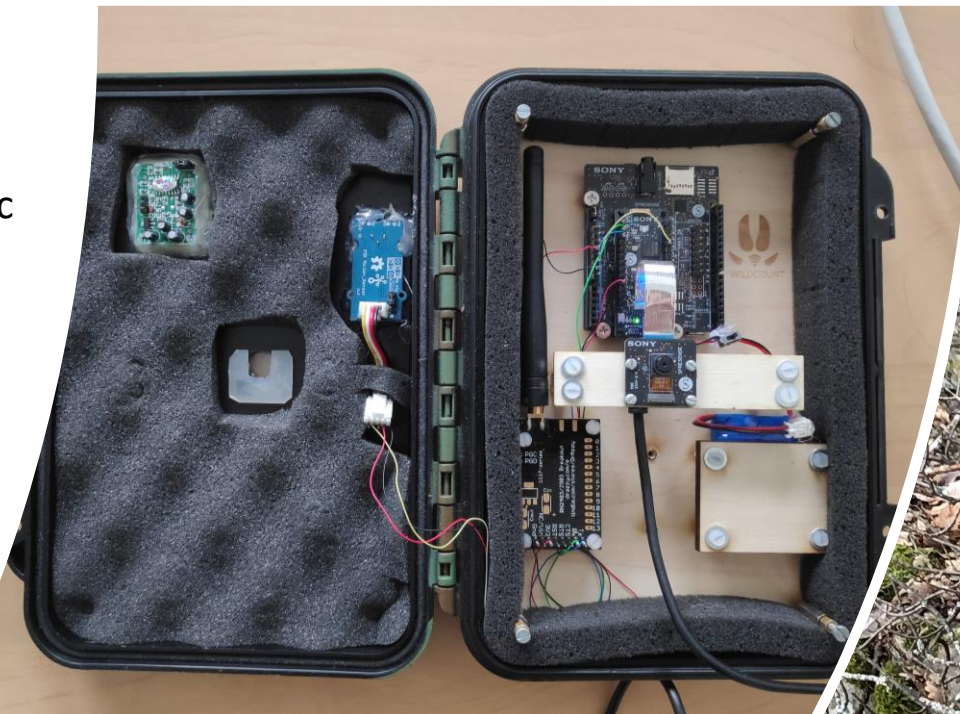

Application : Bird species classification

- Project with CERN
- Use audio and AI to detect and classify bird species
- Sensors deployed in the 211 hectare to follow bird life



Application : Microclimate sensors for Malaria surveillance

- Malaria (WHO, 2021)
 - **247 million cases** worldwide
 - **619,000 deaths** : 25% attributed to **environmental factors**
- Surveillance (IoT)
 - low cost and low tech LoRaWAN weather stations for collecting environmental data
- Prediction/prevention (IA ML)
 - Machine (Deep) Learning for predicting and alerting in case of Malaria epidemic hotspots
- Sites (covered by terrestrial LoRaWAN gateways or sat)
 - Yaoundé (Cameroun), Niamey (Niger)
 - **Remote areas of African countries are badly covered by terrestrial networks**



Introduction

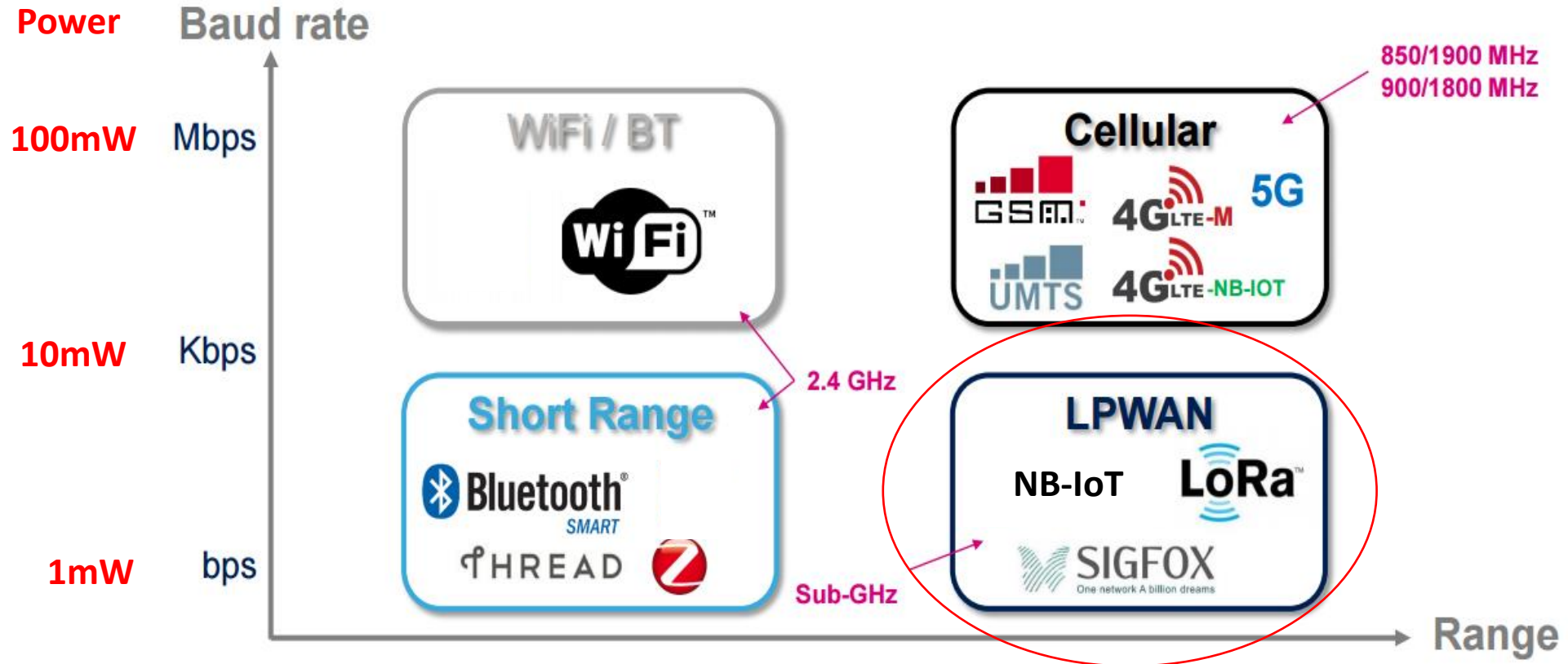

Introduction

Low Earth Orbit reduce communication distance
GEO provide continuous coverage

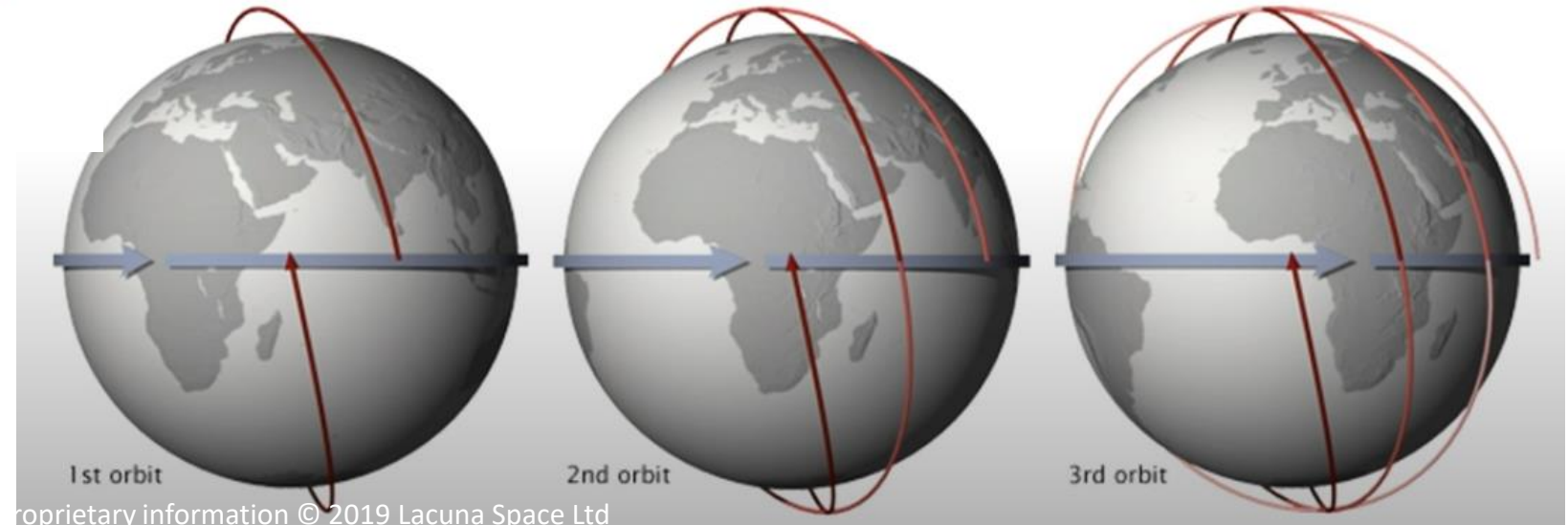
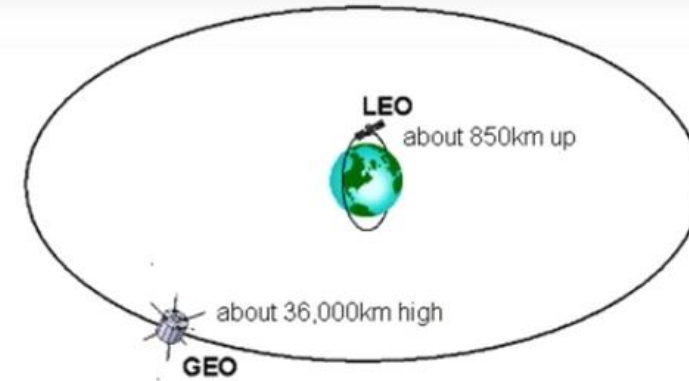
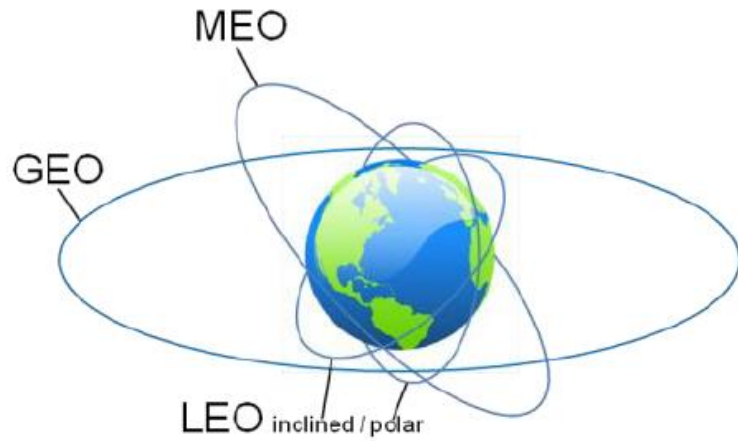

proprietary information © 2019 Lacuna Space Ltd

Introduction

- More satellites means lower revisit time
- Multiple orbits help to increase coverage everywhere
- Most company will start to operate with 4-12 satellites

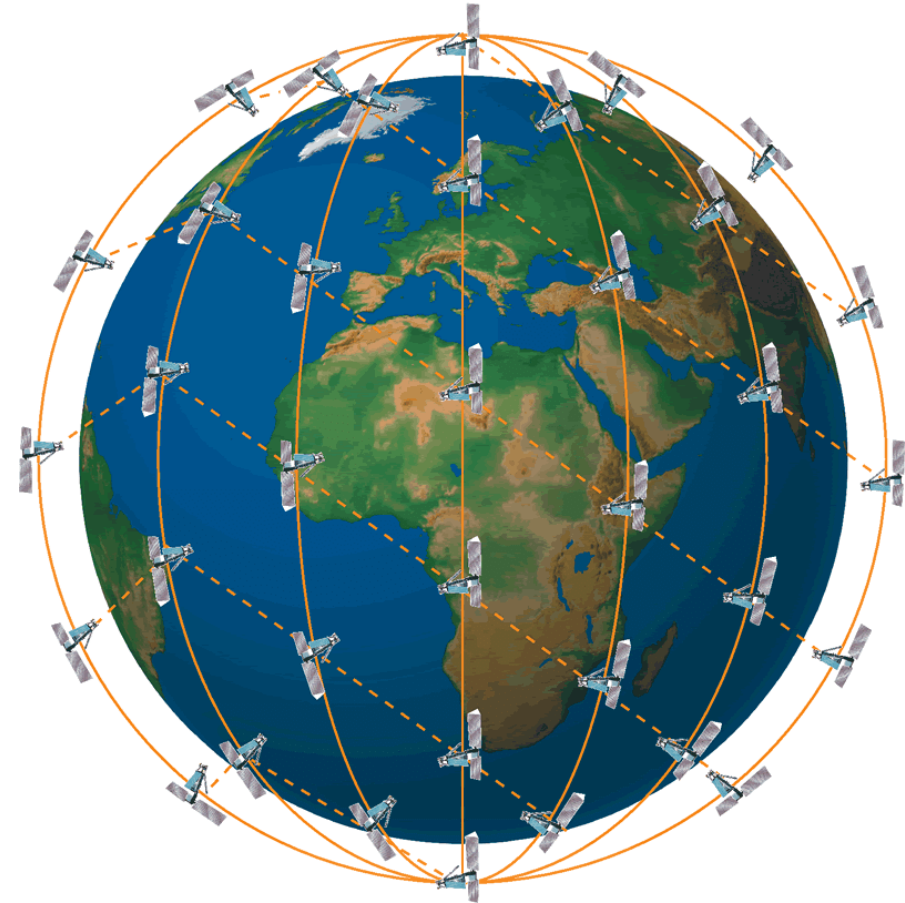
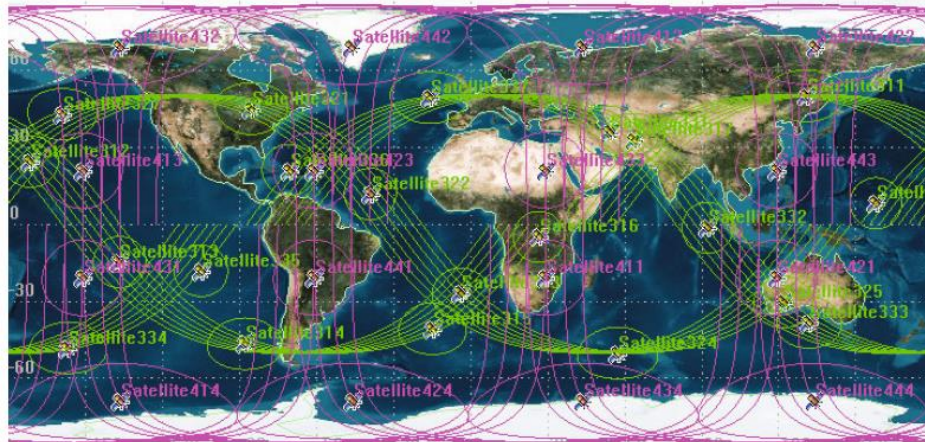

Introduction

Licence bands :

UHF :400MHz : Argos / Kineis

L-band : 1.6GHz : Astrocast

S-band :2-2.2GHz: Echostar/

Omniscpace/ Viasat

C-band : Eutelsat

Ku-band : Eutelsat Iridium



Unlicensed :

433MHz : FossaSat

868MHz : Lacuna, Plan-S

2.4GHz : Orca

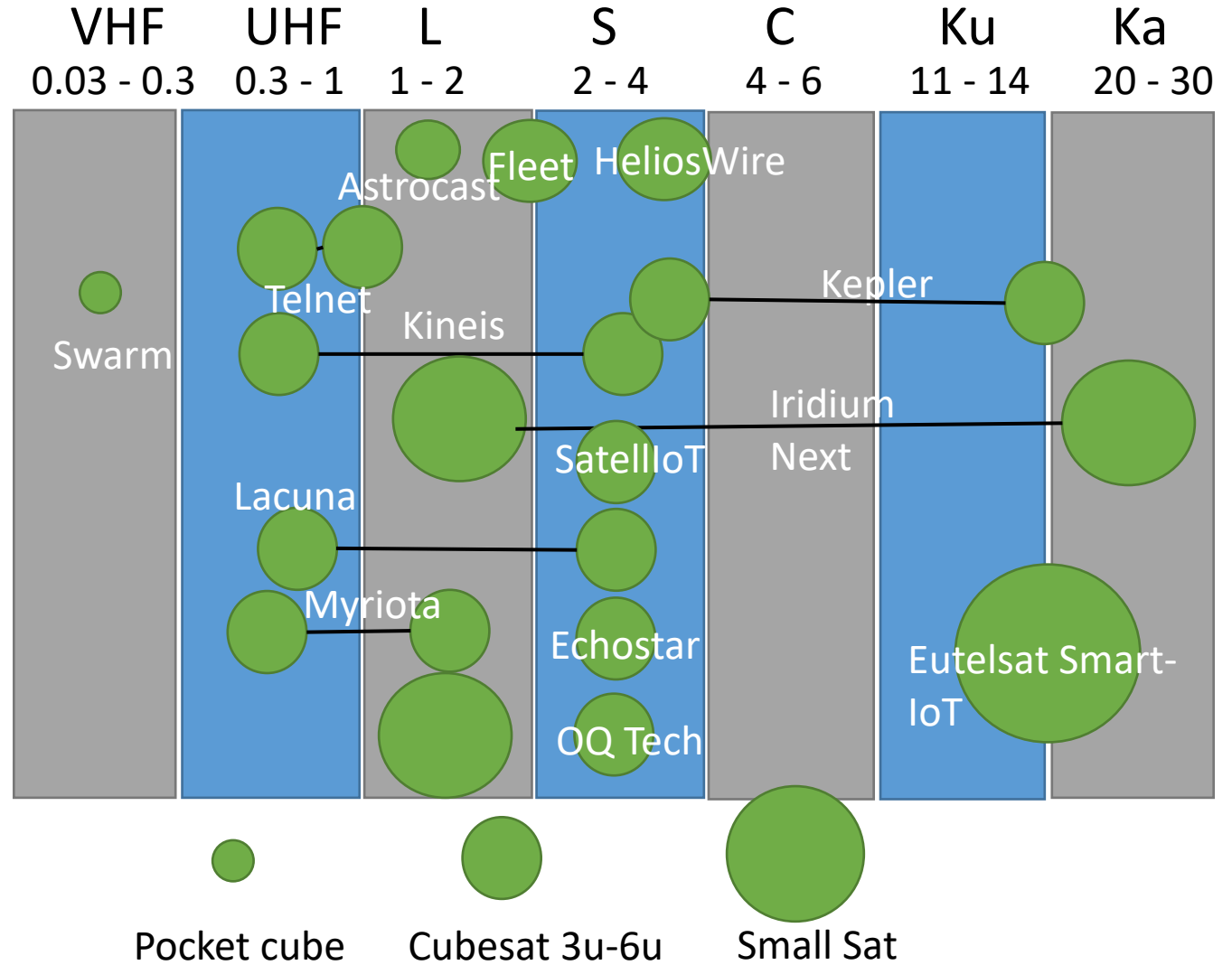

Introduction

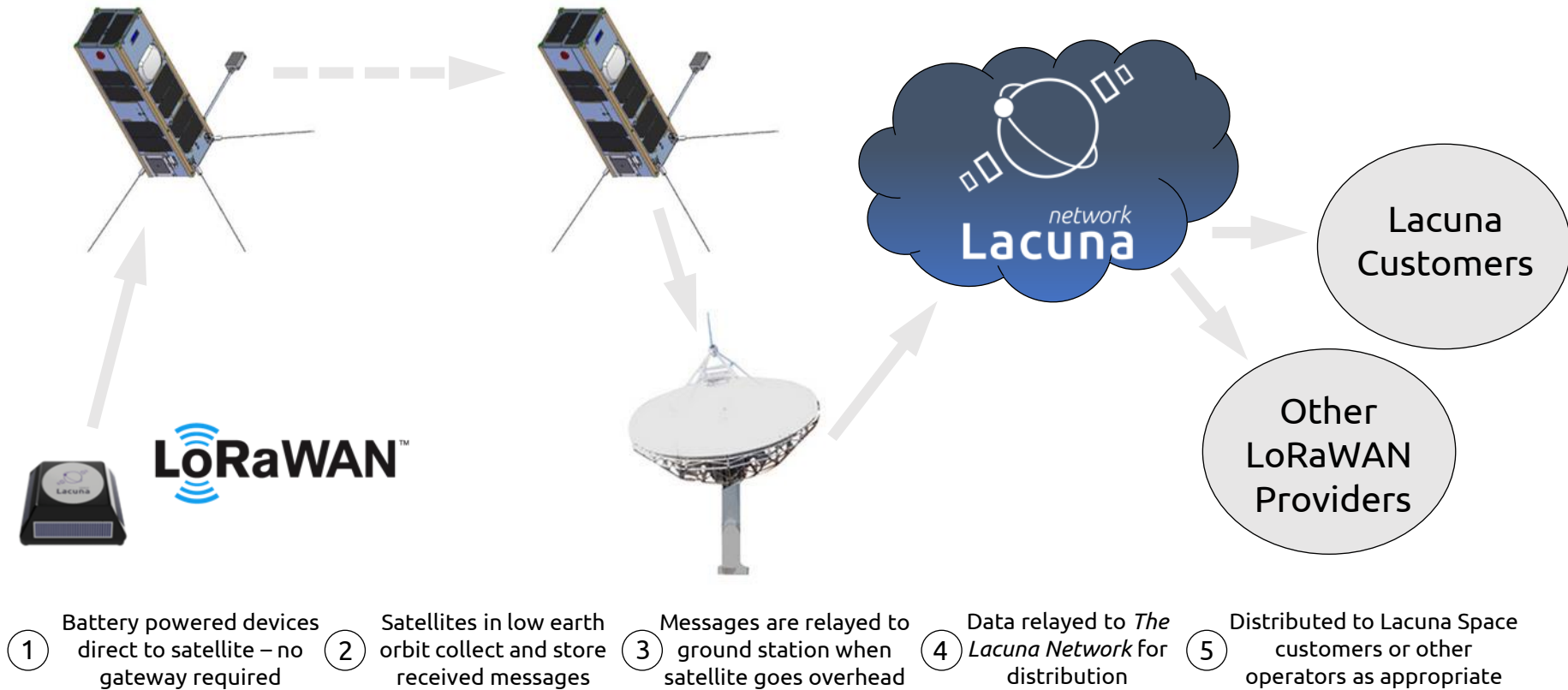

Use ISM bands : 868 or 920MHz

How does the Lacuna technology work?

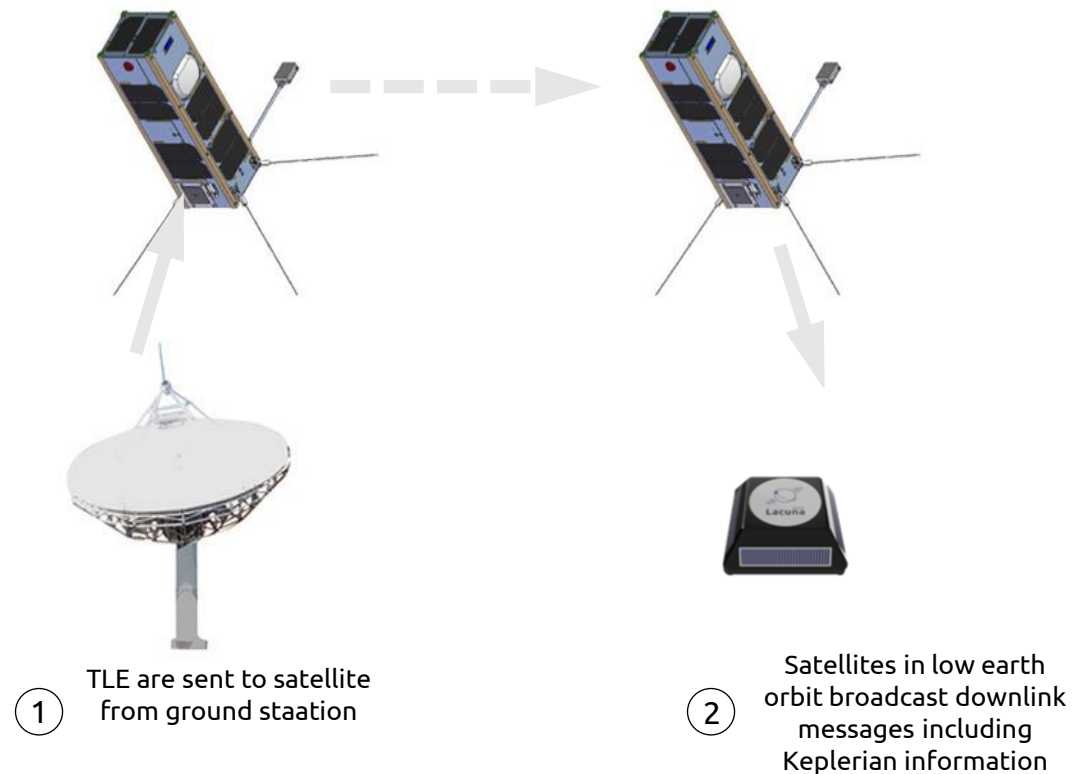

Use ISM bands : 868 or 920MHz

Antenna for IoT from Space

- Ceramic Patch antenna
 - Robust and industrial
 - Cost
- Cross dipole
 - Simple printed structure
 - Need a balun
- Quadri-fillar
 - Wide circularly polarized beam
 - Feeding circuit is complex

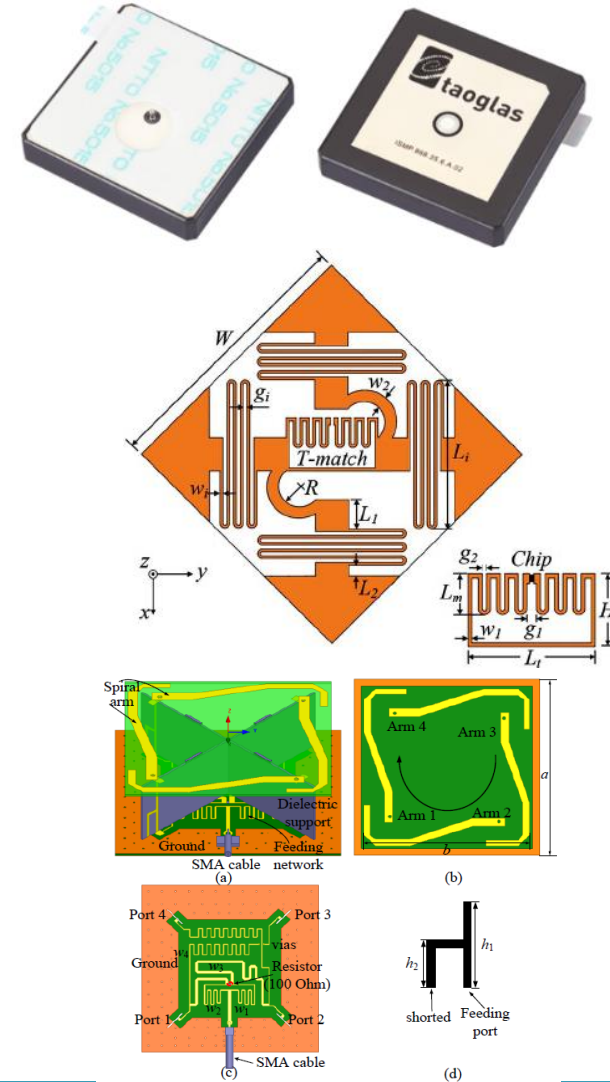

Antenna for IoT from Space

Made on Epoxy FR4 substrate : Top is 0.4mm, Bottom is 0.8mm

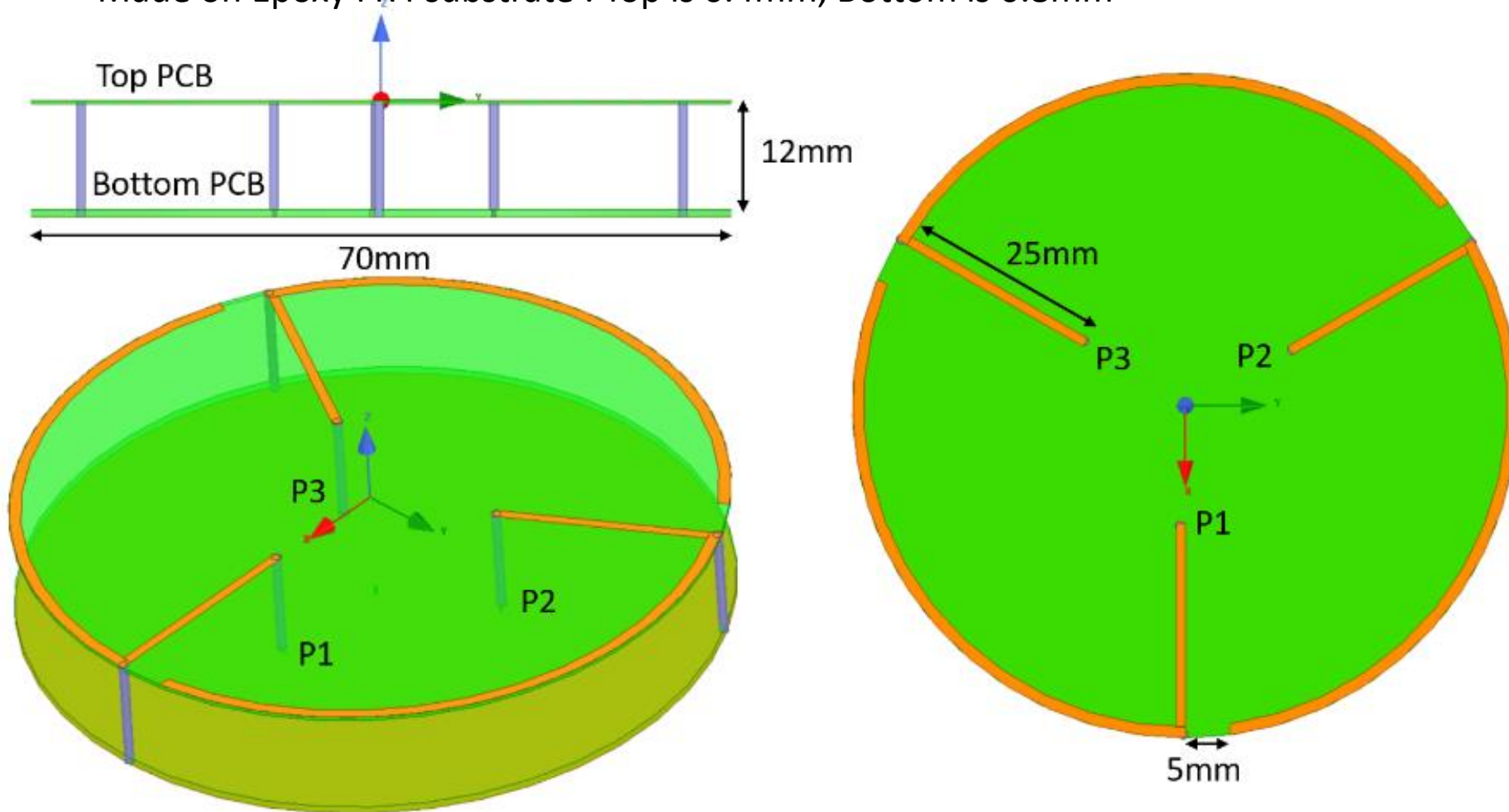

Antenna for IoT from Space

Made on Epoxy FR4 substrate : Top is 0.4mm, Bottom is 0.8mm

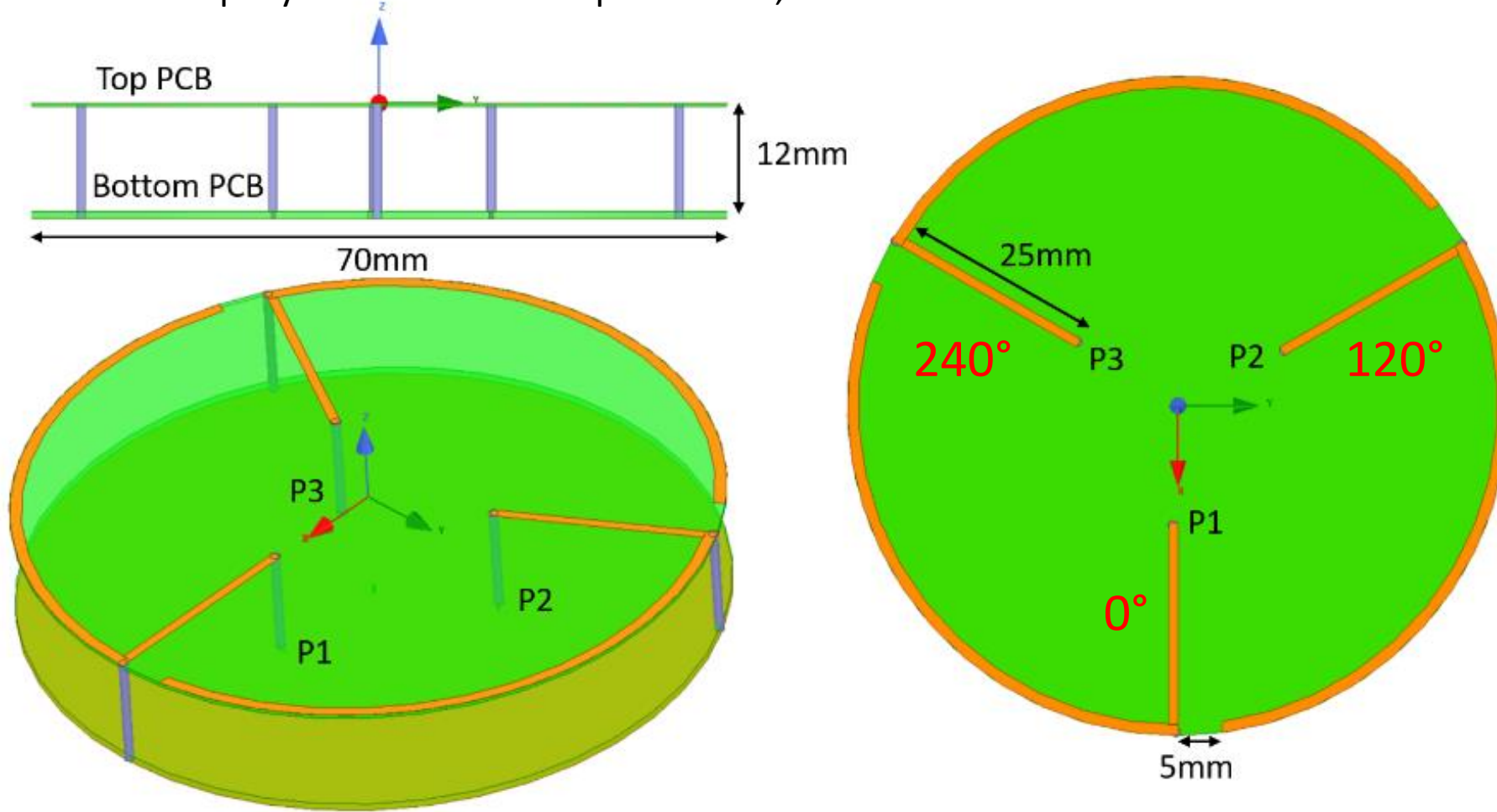

Antenna for IoT from Space

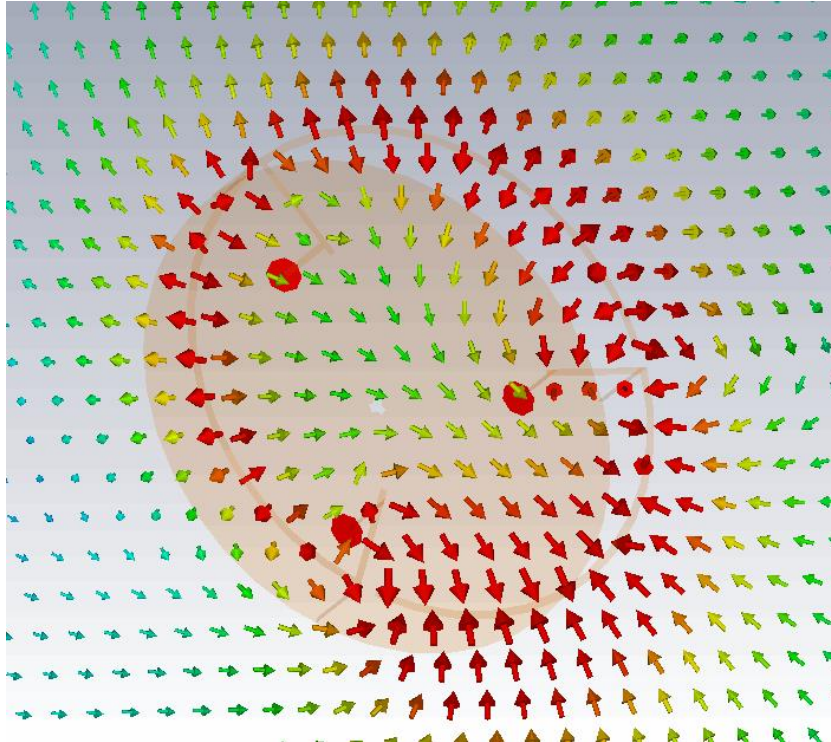

Electric field near the antenna

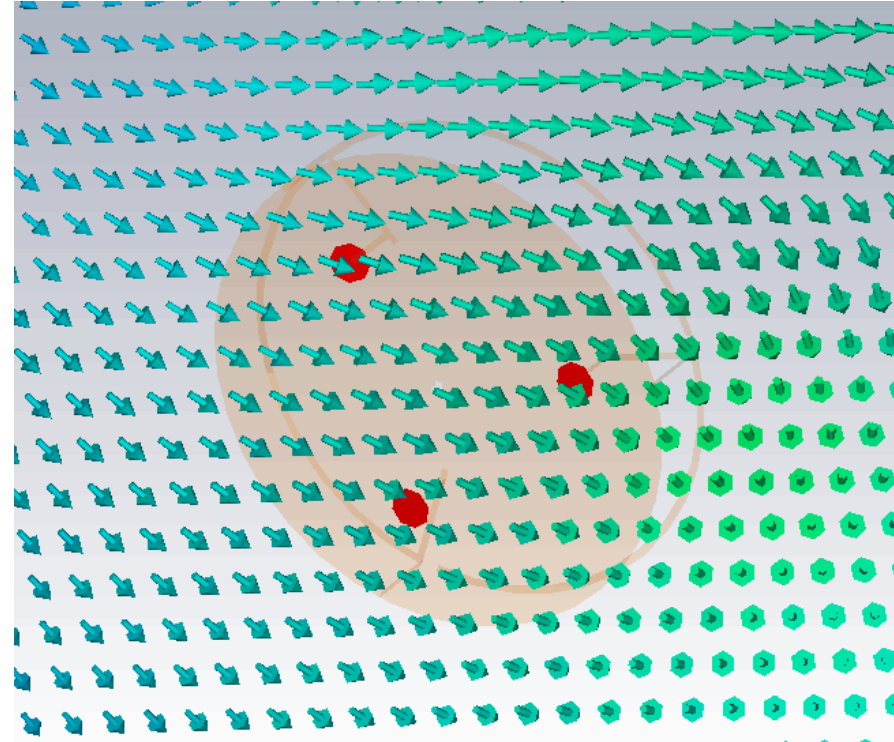

Electric field 5cm from the antenna

Antenna for IoT from Space



Antenna for IoT from Space

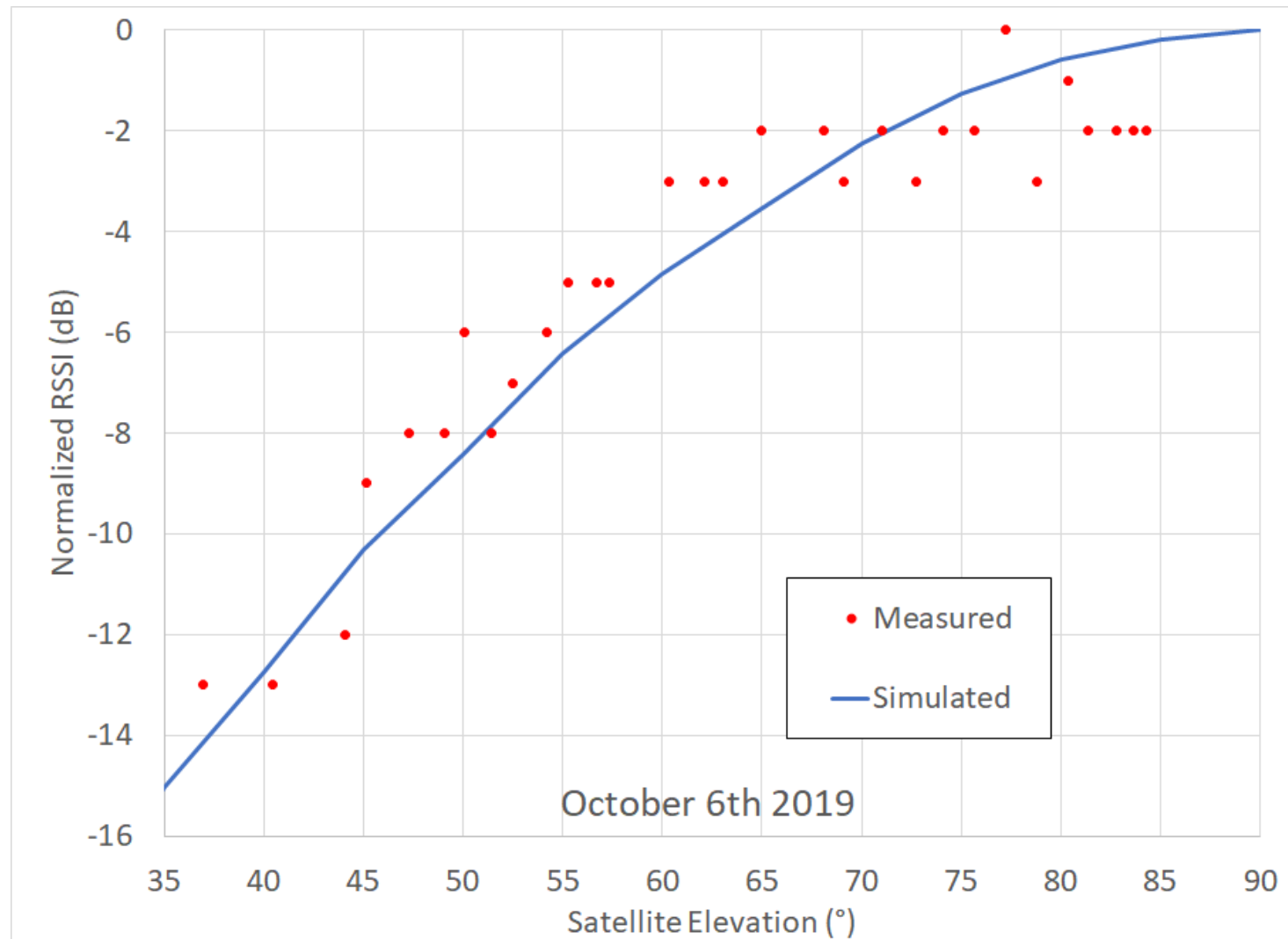

Antenna for IoT from Space

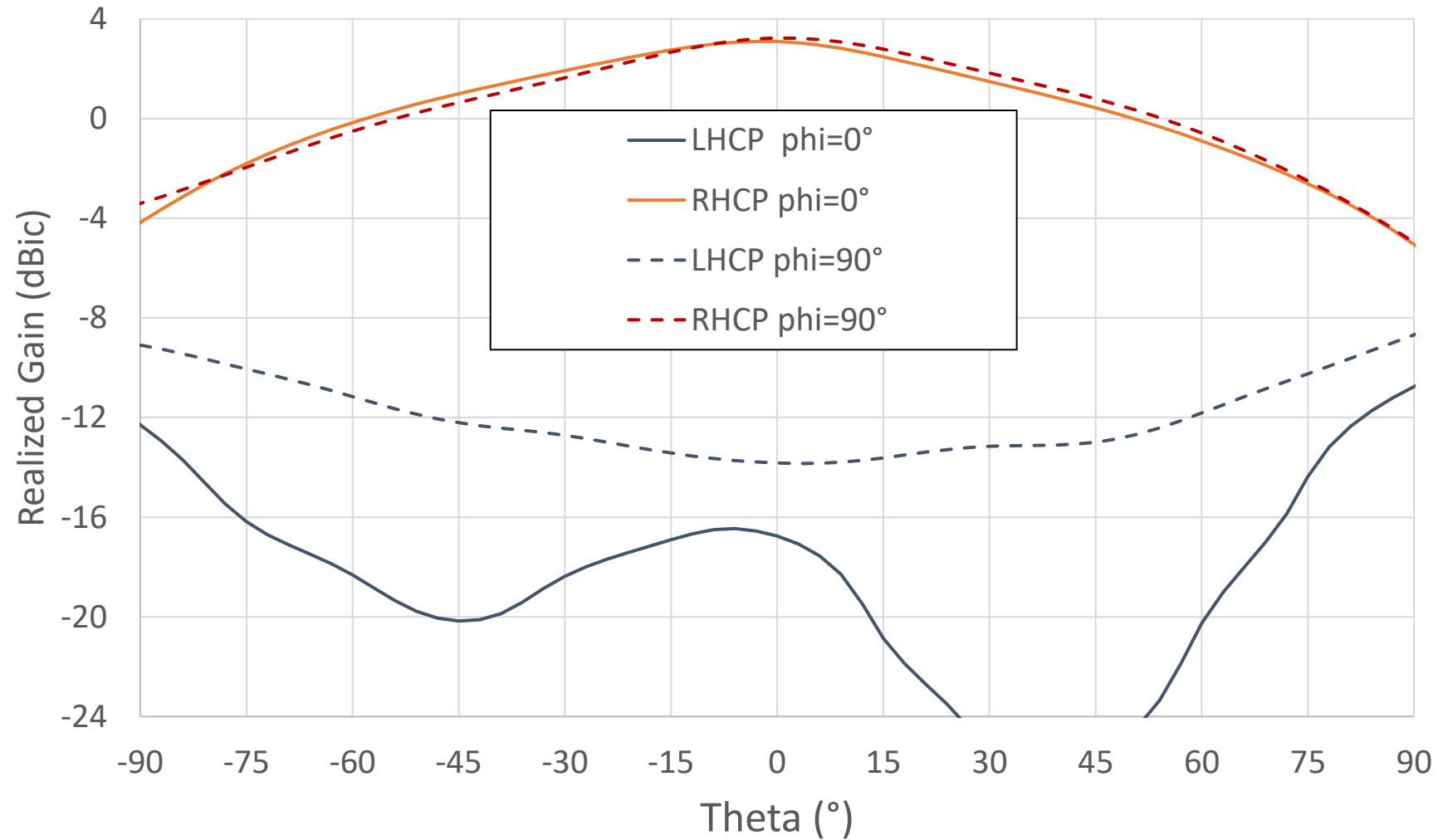

Antenna for IoT from Space

Based on LS-200 Reference Schematic :

- 868/923 RHCP antenna
- SX1262 (LoRa transceiver)
- STM32L476 (1Mb flash)
- Ublox M8Q GPS
- Sensors : Accelerometer, Air quality, ..
- Hall sensor

Sleep power : 20uA

Relay mode : 60uA

Several years of autonomy with a single battery



Lauréats de l'appel à projets « hardware » mené en 2021 par l'Académie "Réseaux, Information et Société numérique" (RISE)

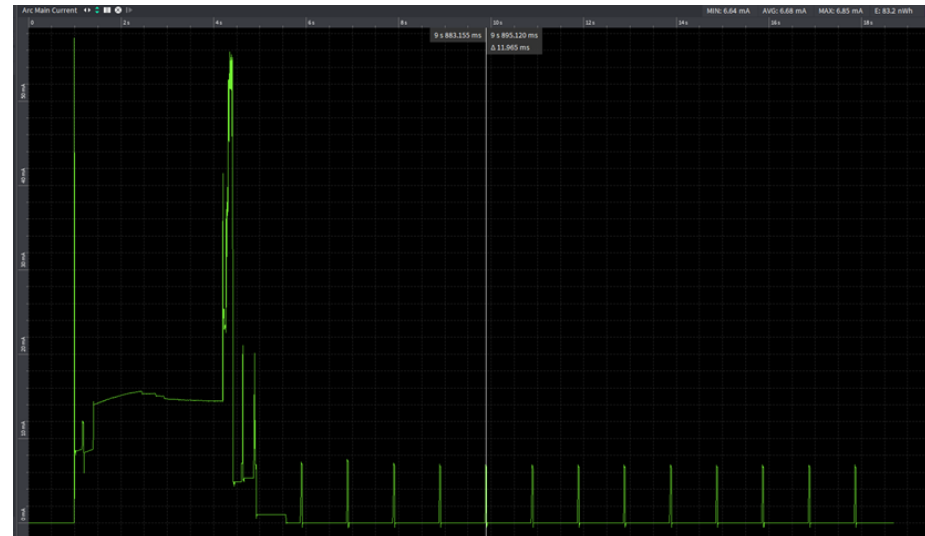

Antenna for IoT from Space

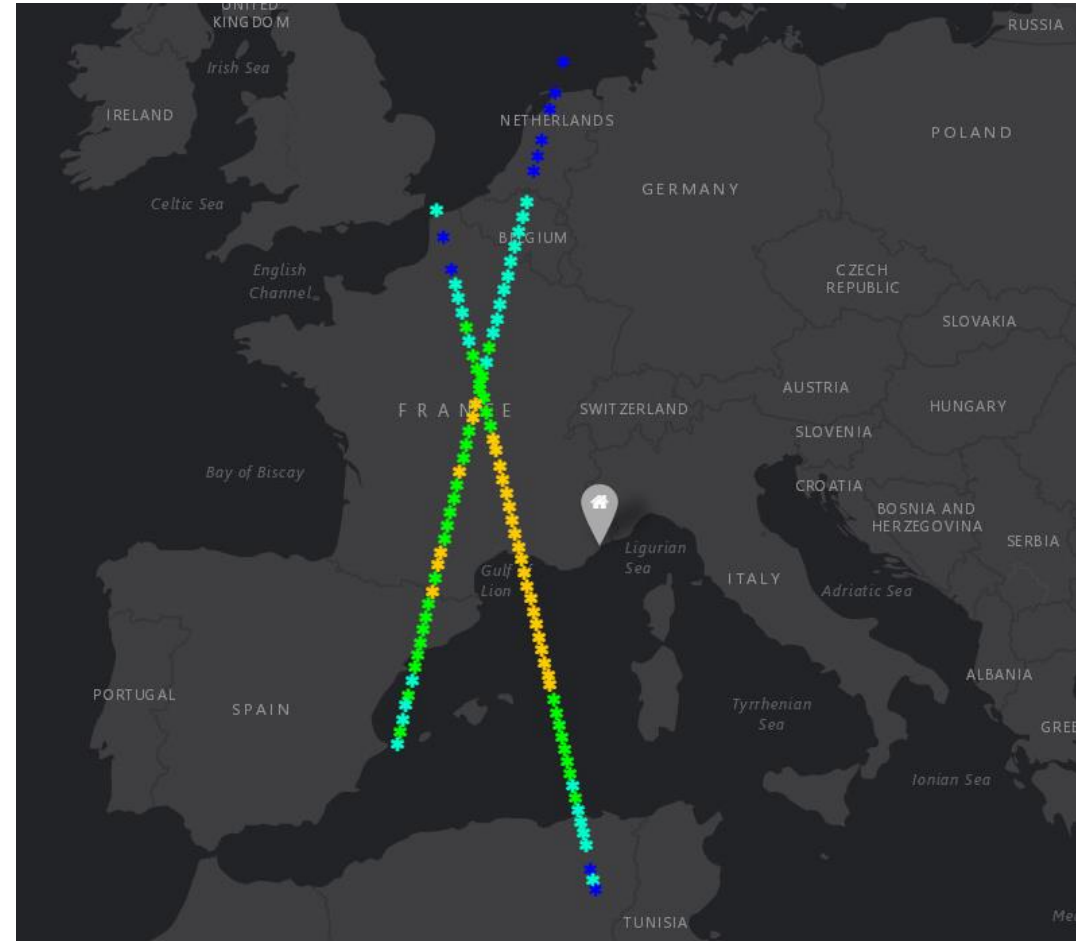
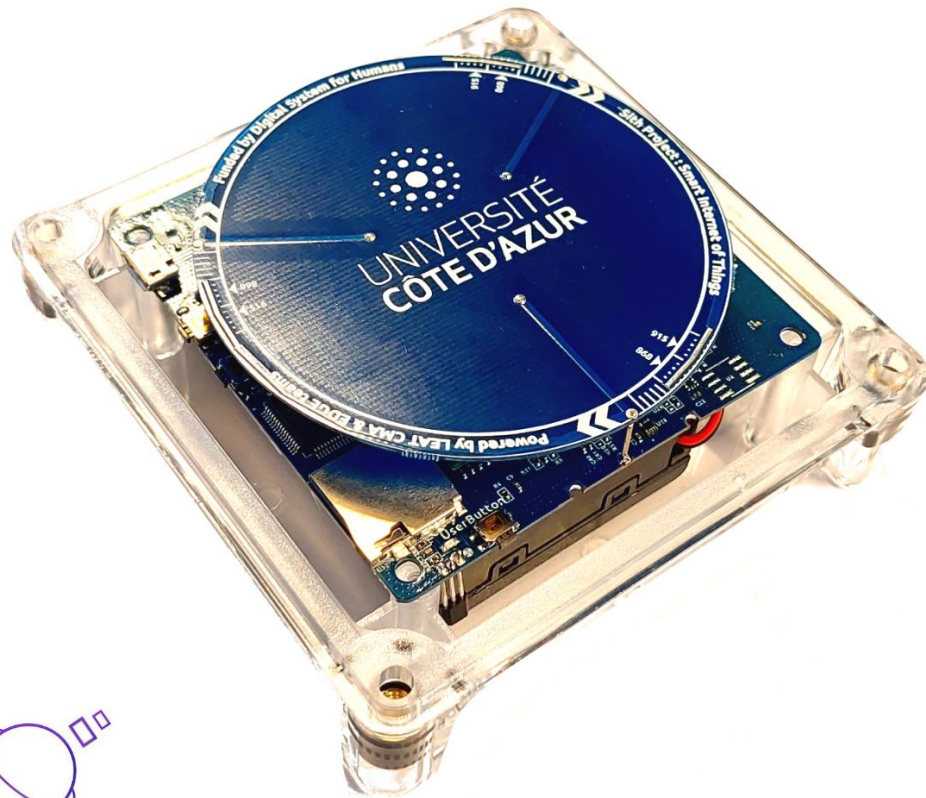

Experiments

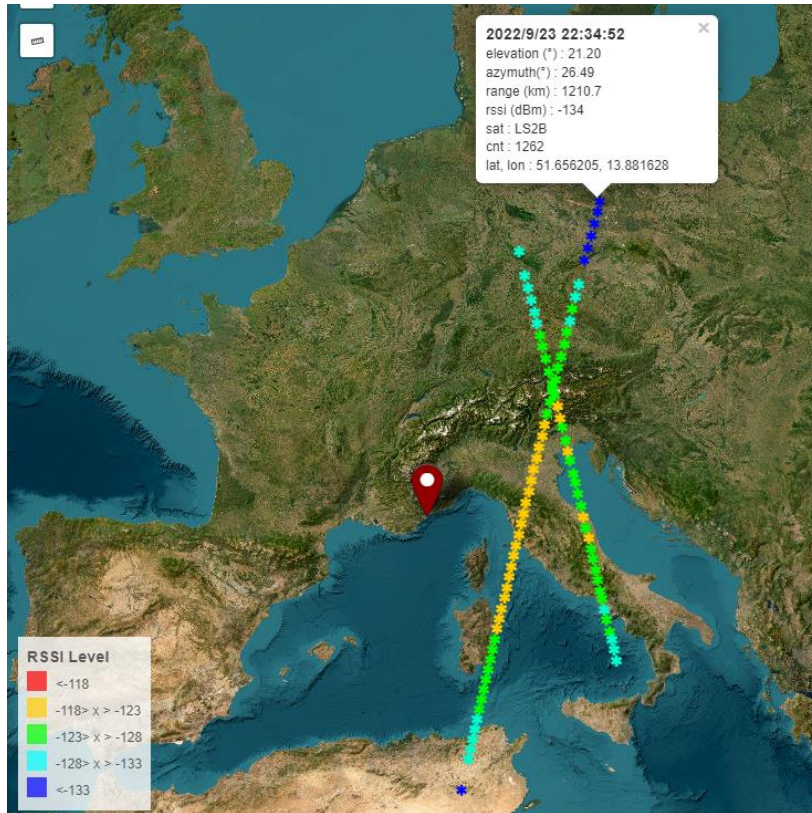

LS2D (polar orbit)



LS2C (37° inclination orbit)

Communication down to 20° of elevation

Experiments

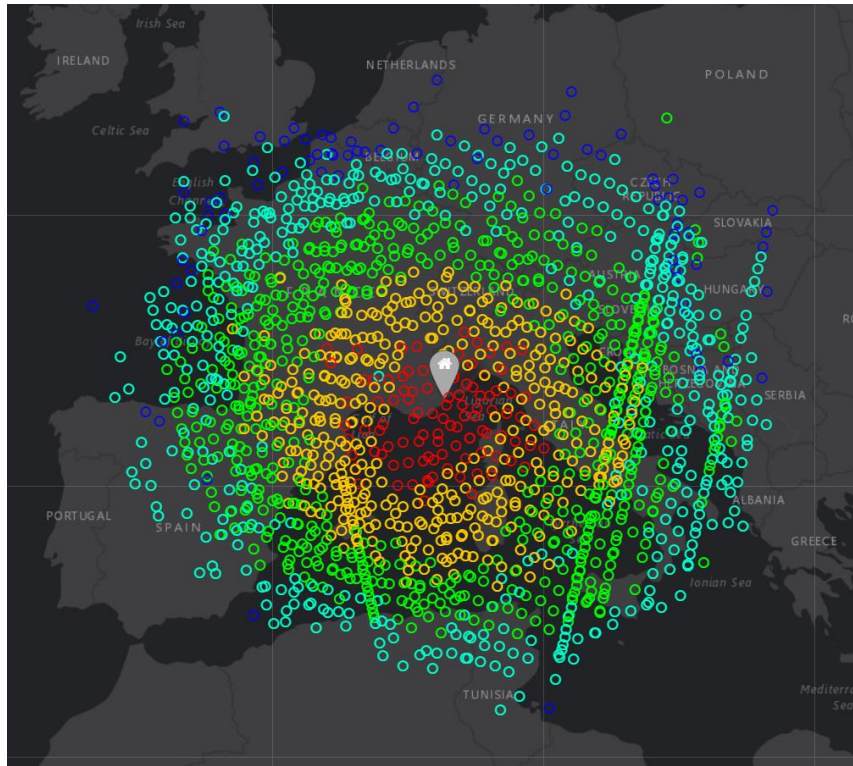

LS2D (polar orbit)

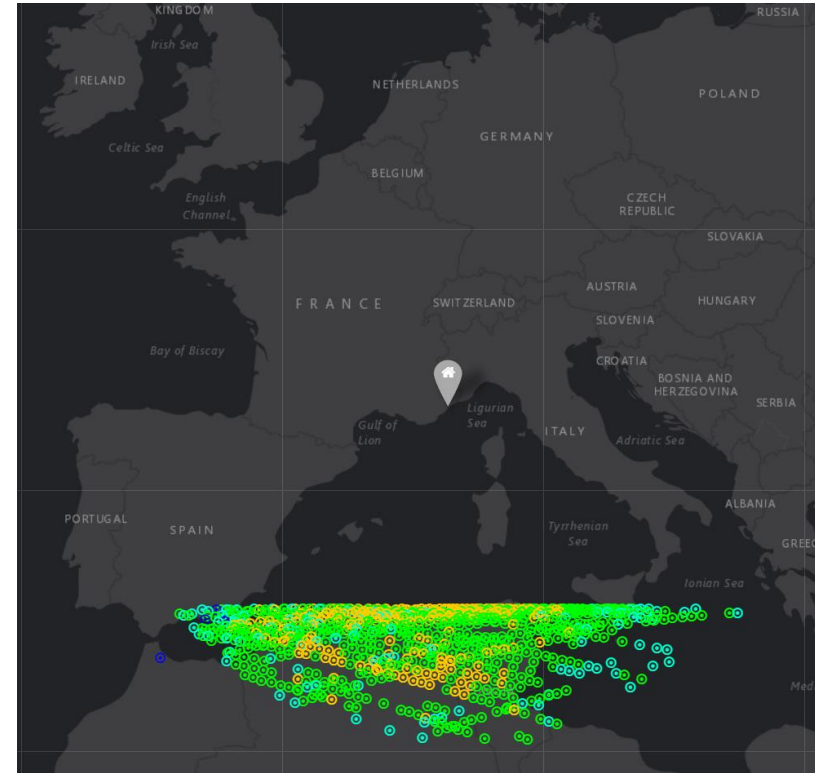

LS2C (37° inclination orbit)

Communication down to 20° of elevation

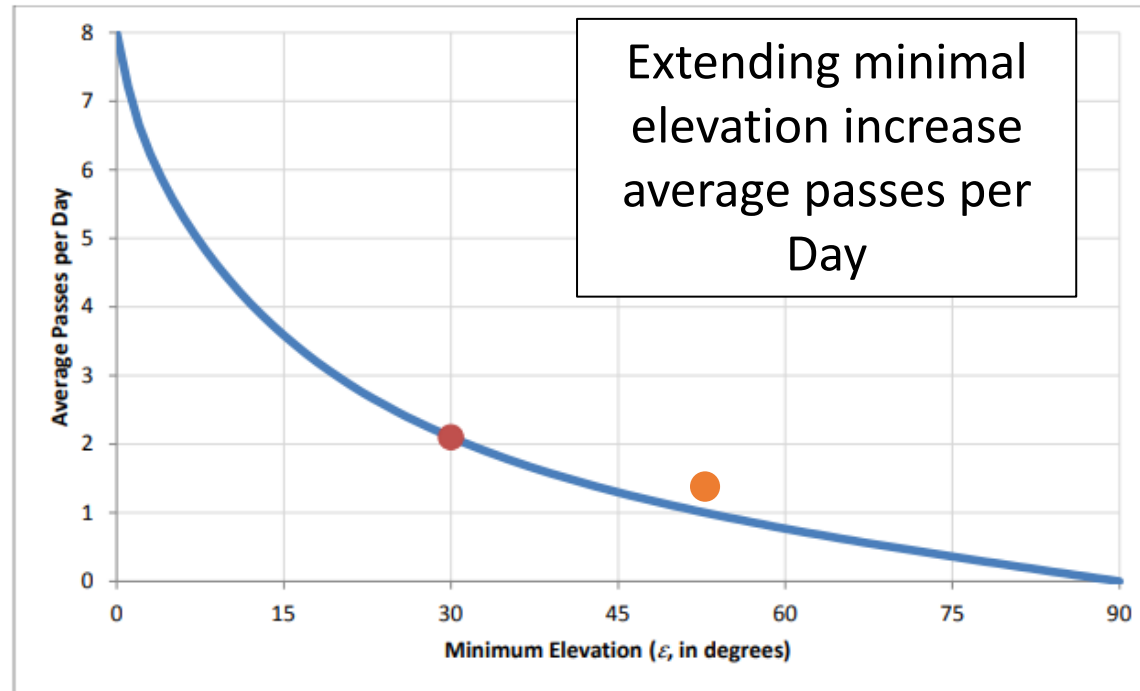

“A Closed-Form Approximation of Revisit Rate for Low-Altitude Spacecraft” Dr. Roger Chapman Burk, Ph.D

Parameter	Base Value	Remarks	Variation	Remarks
Inclination (i)	60°	Good temperate-zone coverage	0-90°	Retrograde orbits are similar
Altitude (h)	680 km	Similar to altitudes of Ikonos and GeoEye commercial imagery spacecraft	350-1000 km	Covers almost all LEO satellites in NORAD catalog
Minimum Elevation (ϵ)	30°	Allows reasonable imaging	0-90°	
Latitude (L)	35°	Malta, Kirkuk, Tehran, Tokyo, Albuquerque, Memphis (TN); Buenos Aires, Sydney	0-90°	North and south latitudes give identical results

Experiments

- From 0 to 20cm height
- From 26th December 2020 to 6th January 2021
- 17dBm output power (respecting EU regulation)



Experiments

- Ground is strongly impacting antenna pattern
- Can create isoflux pattern

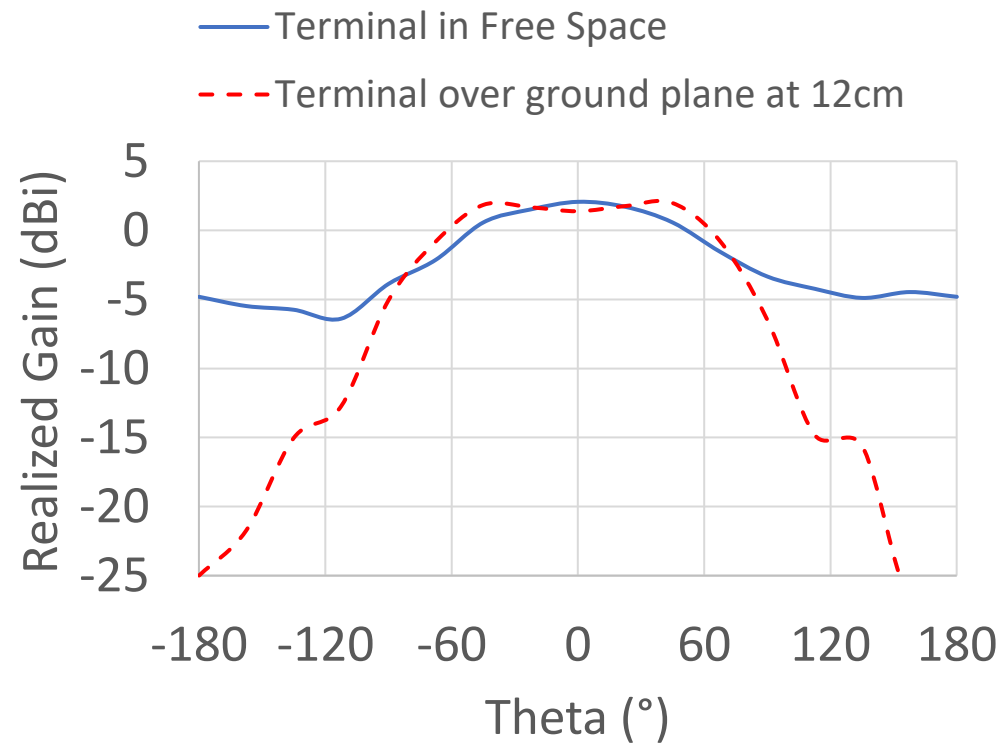

Experiments

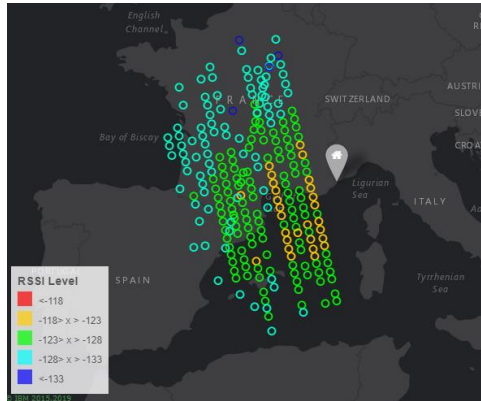

0cm

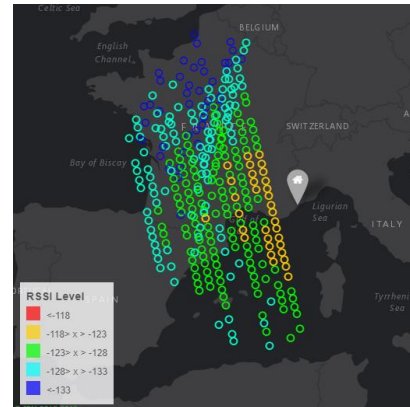

5cm

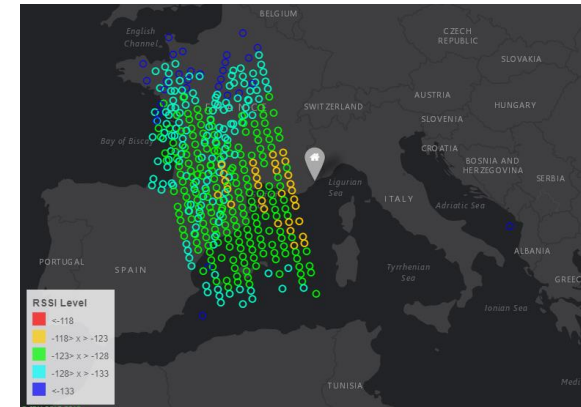

10cm

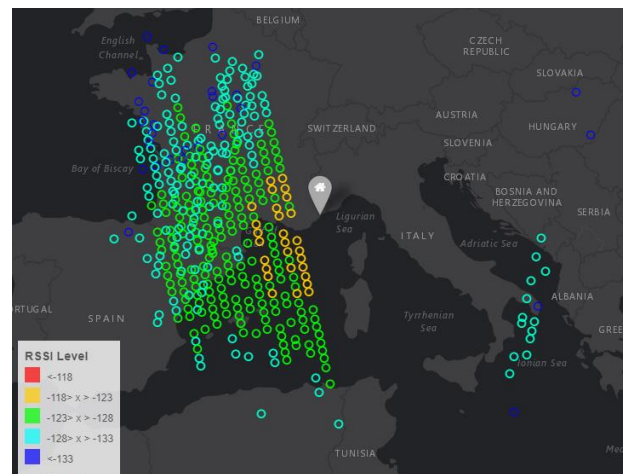

15cm

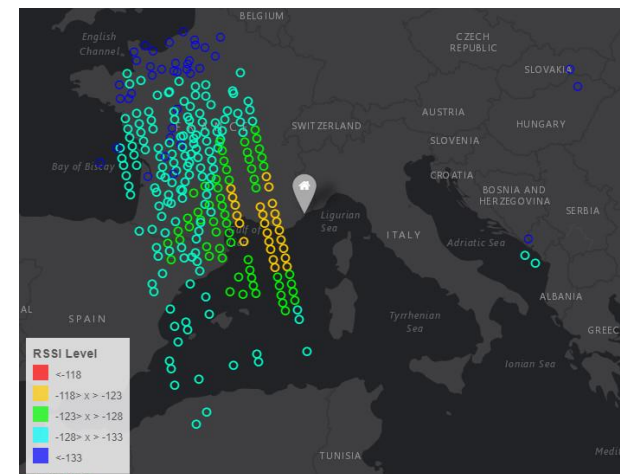

20cm

Relay mode : extending the coverage

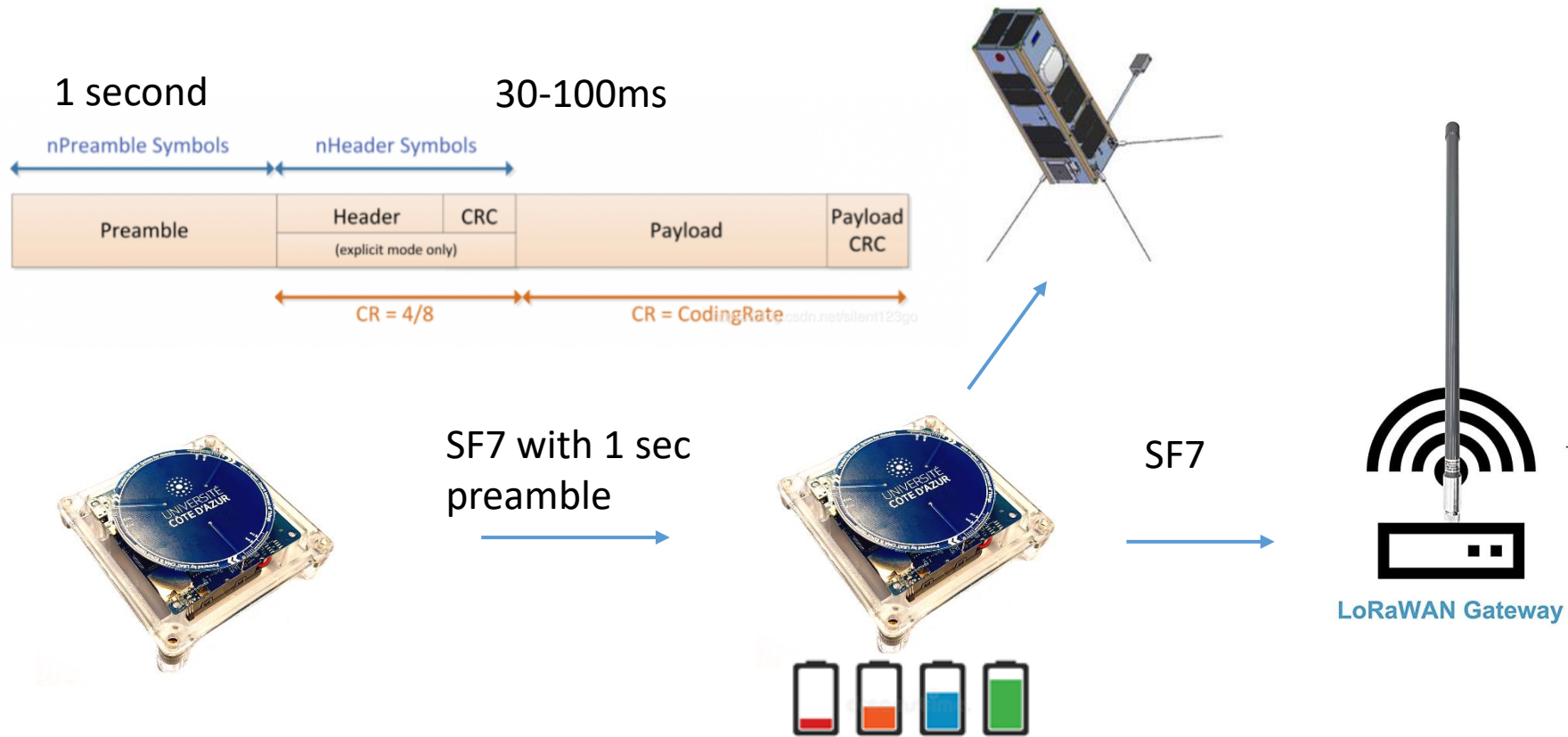

- Relay lorawan message
- Optimize relay power consumption thanks to duty cycled Rx

Relay mode : extending the coverage

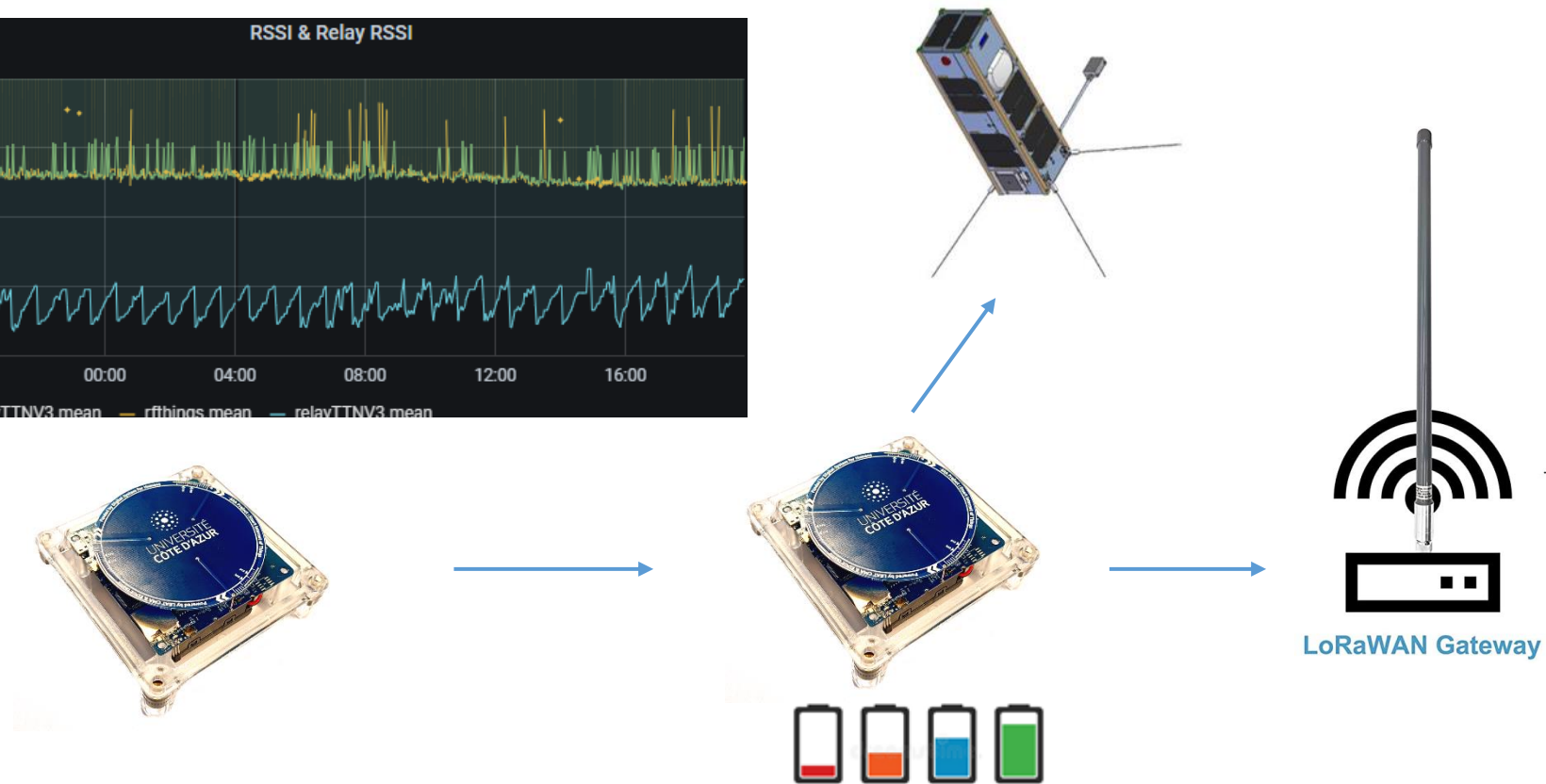
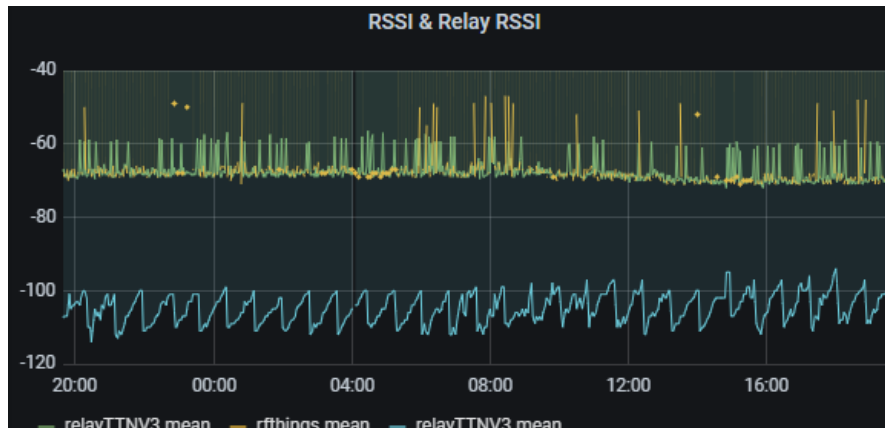

- Relay sensitivity : -115 to -120 dBm
- Average power consumption : 70uA

Omnispace with MEO : ICO F2 (S-band)

10000km from Earth

Inclination 44°

Period : 6H

Every day: 2H of bidirectional communication

LS300 Lacuna terminal is available

S-band licence needed to operate in the country

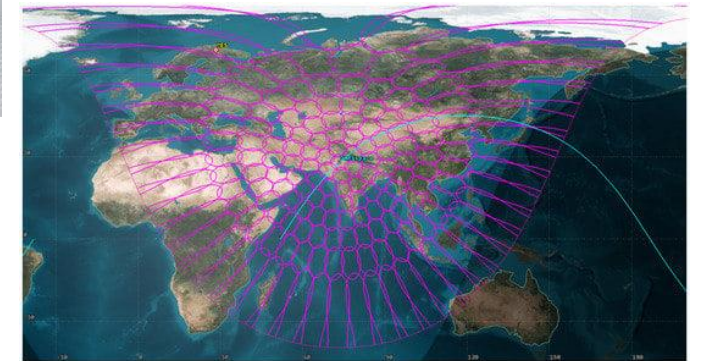

Echostar with GEO : ECHO XXI (Terrestar2)

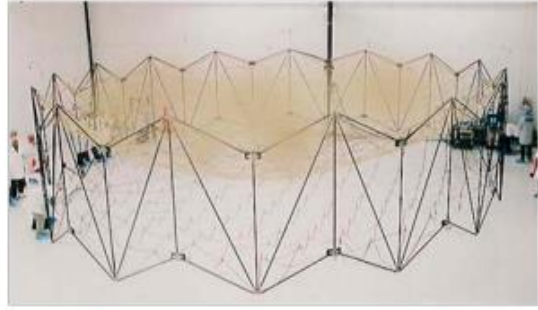
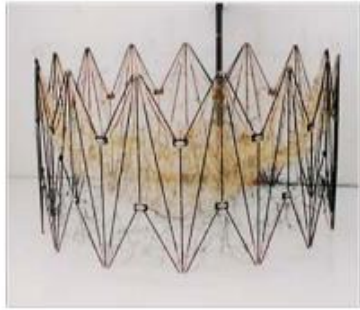

12m AstroMesh

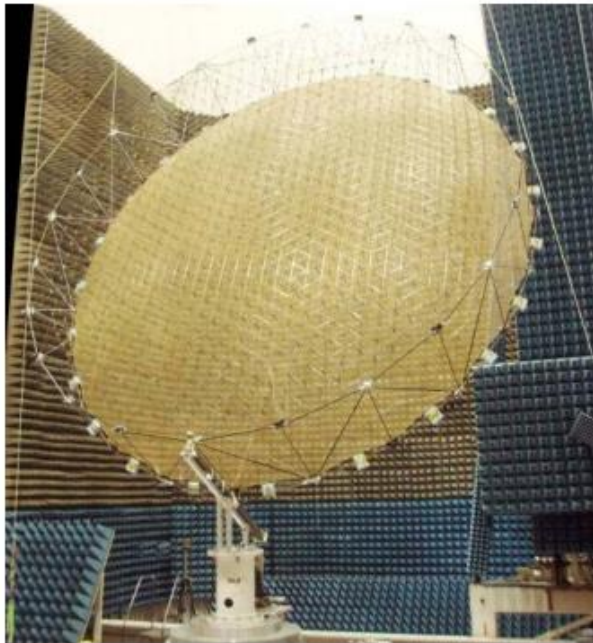

18m reflector to create regional cells on the ground

45° elevation south

Gain : 50dBi per beam

S-band



Echostar budget link ceramic linear antenna

- Geostationary orbit : 36000km
- Attenuation @2GHz : 190 dB
- Rx sensitivity : -135dBm (SF12)
- Margin : 6dB (depend on your application)
- Fading effect : 4-8dB (multi-path)
- Kit avg Antenna gain : -1dBi
- Linear to CP loss : 3dB
- Satellite Gain (18m dish) : 50dB

Tx power terminal : 19-23dBm

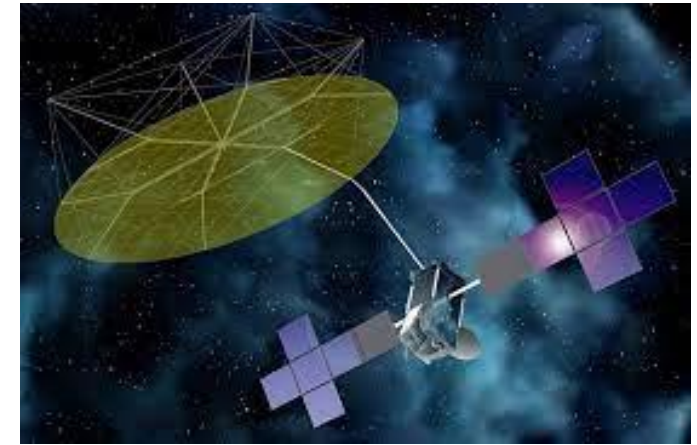

36000km



Echostar budget link with CP antenna

- Geostationary orbit : 36000km
- Attenuation @2GHz : 190 dB
- Rx sensitivity : -135dBm (SF12)
- Margin : 6dB (depend on your application)
- Fading Effect : 2-4dB
- Avg Antenna gain : 0dBic
- ~~Linear to CP loss : 3dB~~
- Satellite Gain (18m dish) : 50dB

Tx power terminal : 13-15dBm



36000km

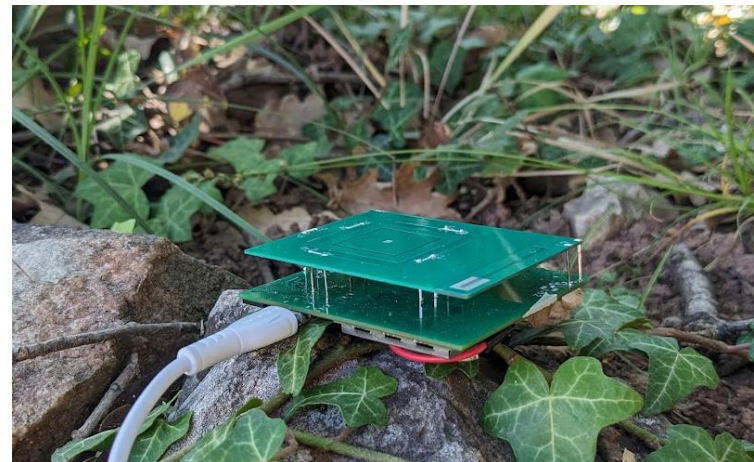

Antenna development

- Size : 50*65*10mm
- S-band Left Hand Circularly Polarized Antenna
- L-band Right Hand CP antenna for GNSS
- UHF miniature antenna for 868MHz

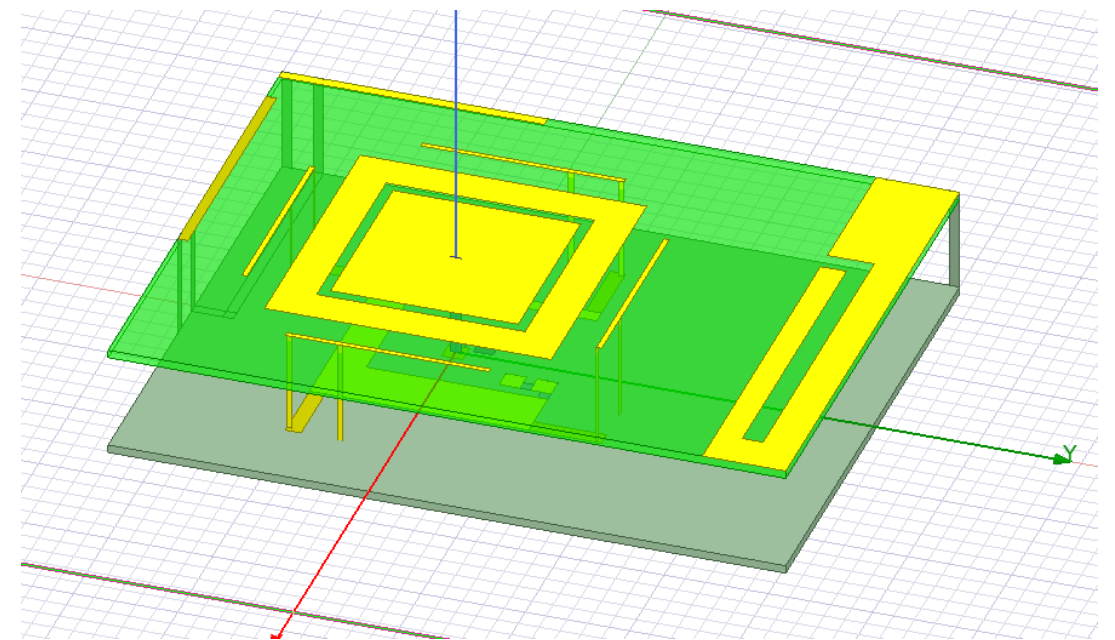

S-band Antenna Measurement

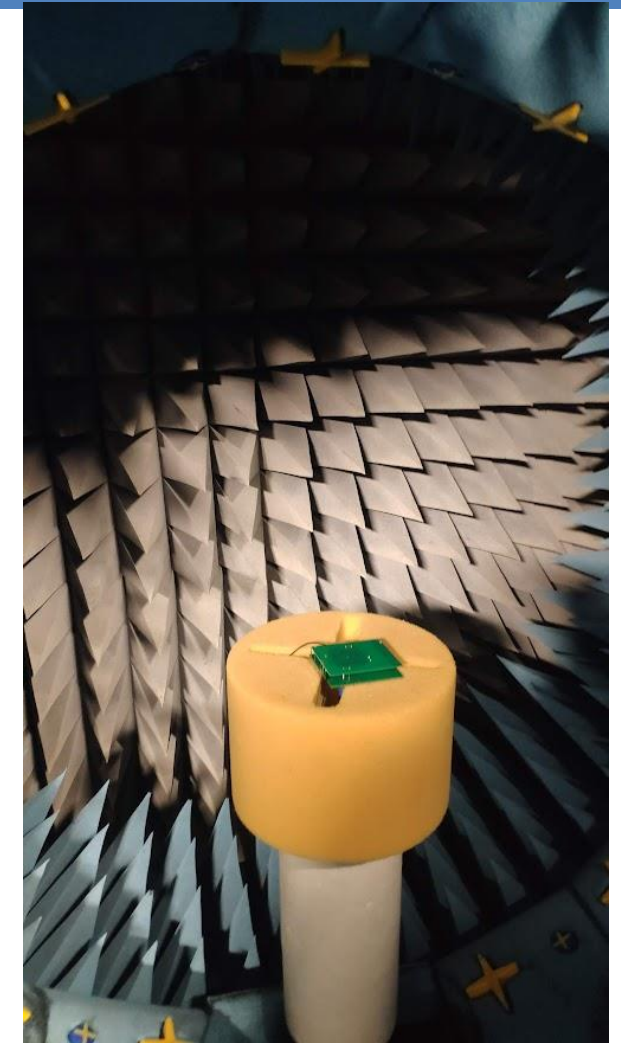
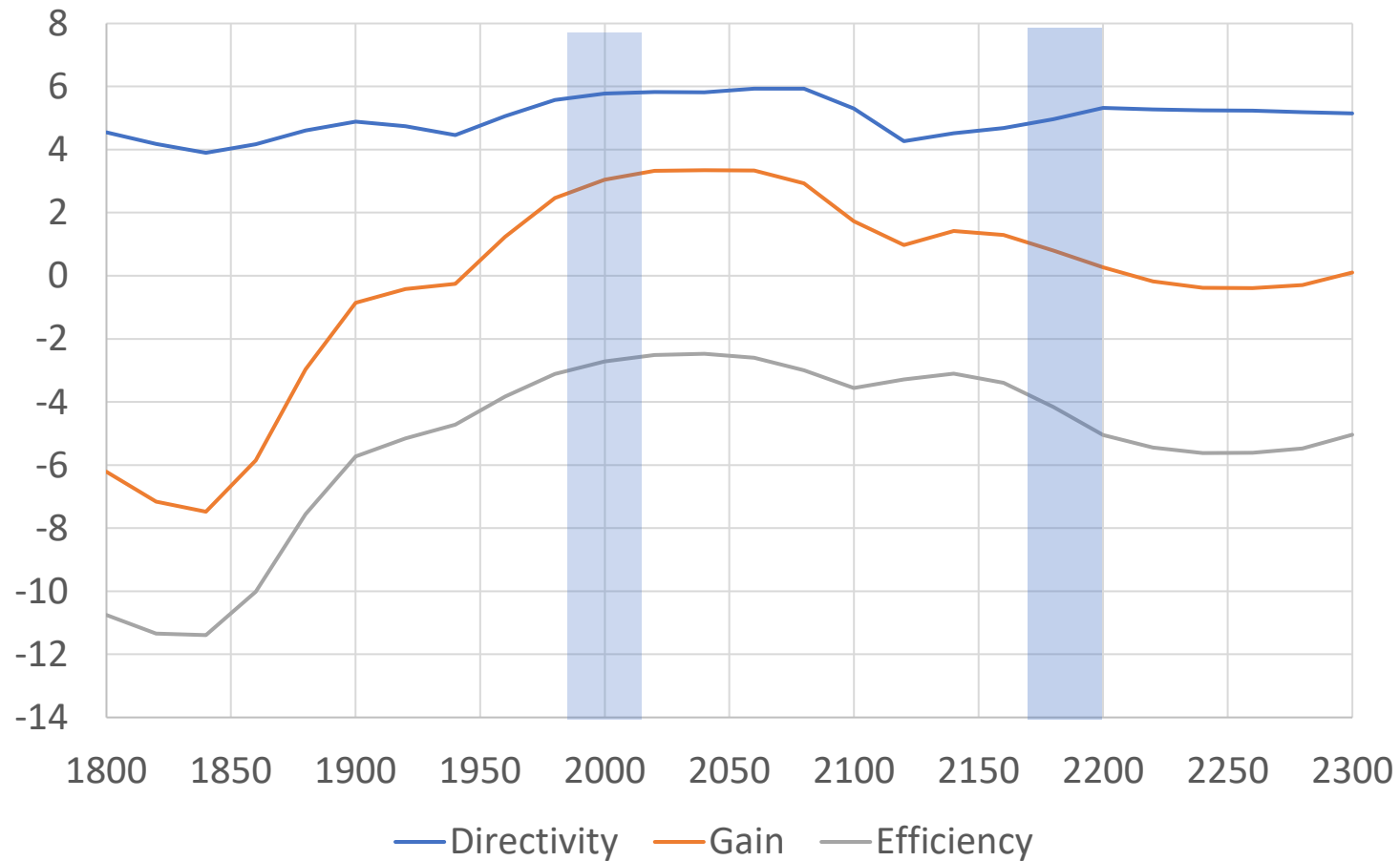

S-band Antenna Measurement

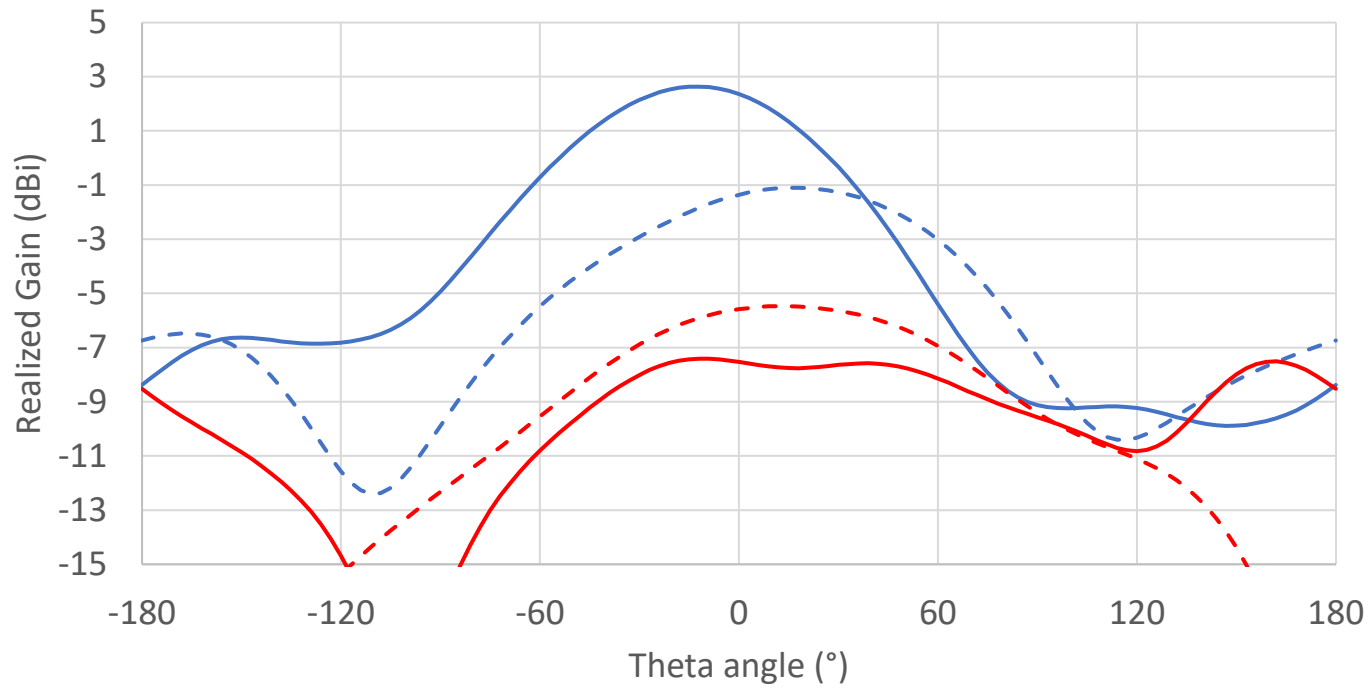

— 90 2000.00 ELHCP
— 90 2000.00 ERHCP

- - - 90 2200.00 ELHCP
- - - 90 2200.00 ERHCP

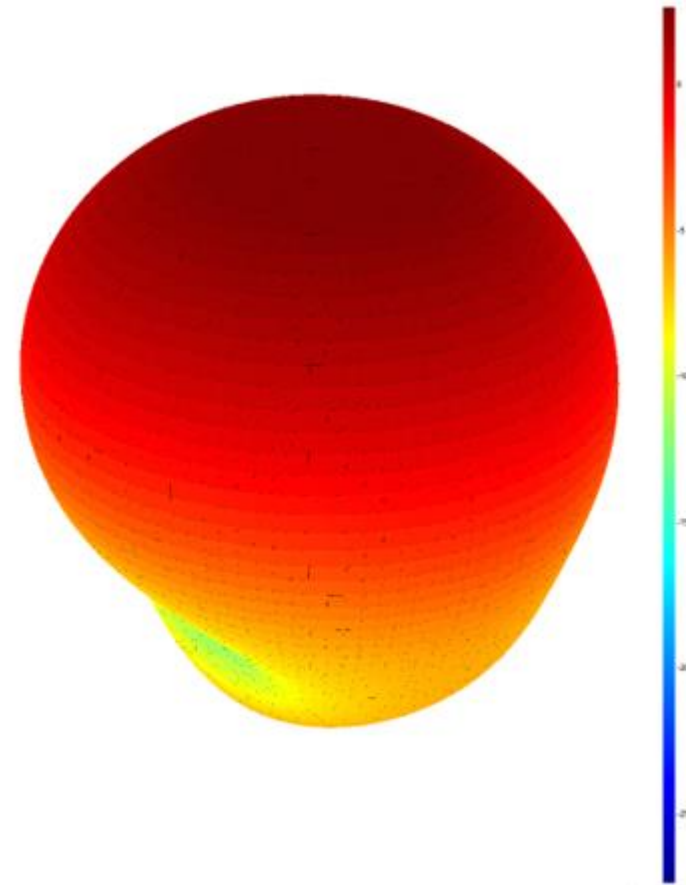

Test with Tx = 0dBm (1mW)

- SNR -14 to -16dB
- Low impact from human body effect

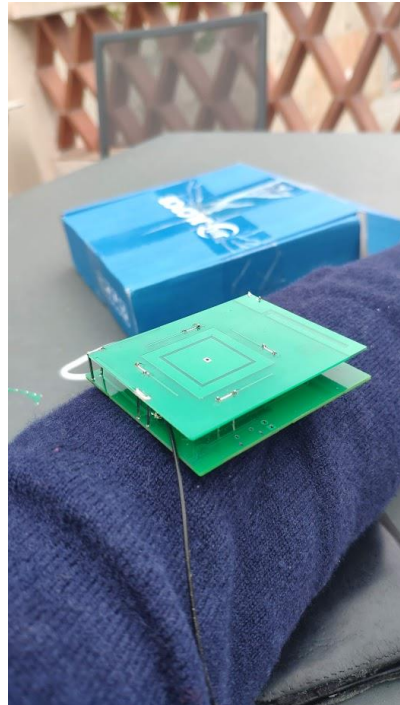

Terminal development

- Size : 50*65*10mm
- Module EM2050
- STM32WB5MMGH6TR module
- S-band Left Hand Circularly Polarized Antenna
- L-band Right Hand CP antenna for GNSS
- UHF miniature antenna for 868MHz

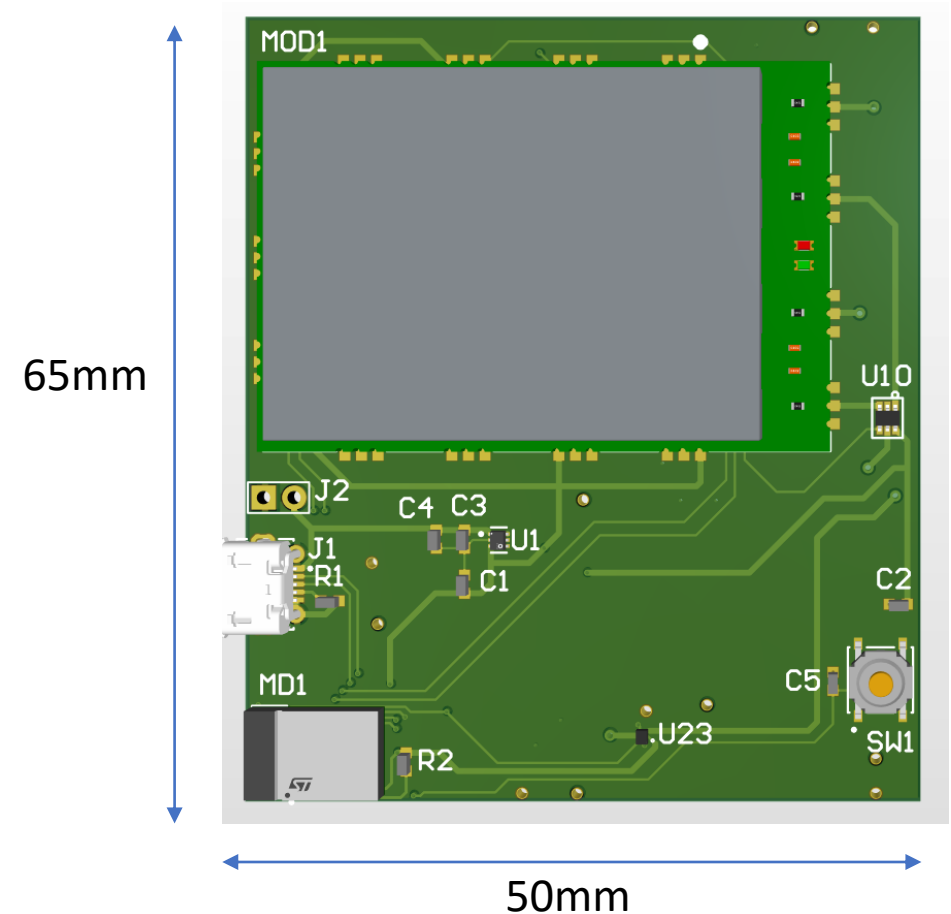

Terminal development

- Size : 50*65*10mm
- Module EM2050
- STM32WB5MMGH6TR module
- S-band Left Hand Circularly Polarized Antenna
- L-band Right Hand CP antenna for GNSS
- UHF miniature antenna for 868MHz



Test with 14dBm

- 4*AAA battery
- SNR -11 to -15dB
- Still 6 dB difference with antenna alone -> work in progress

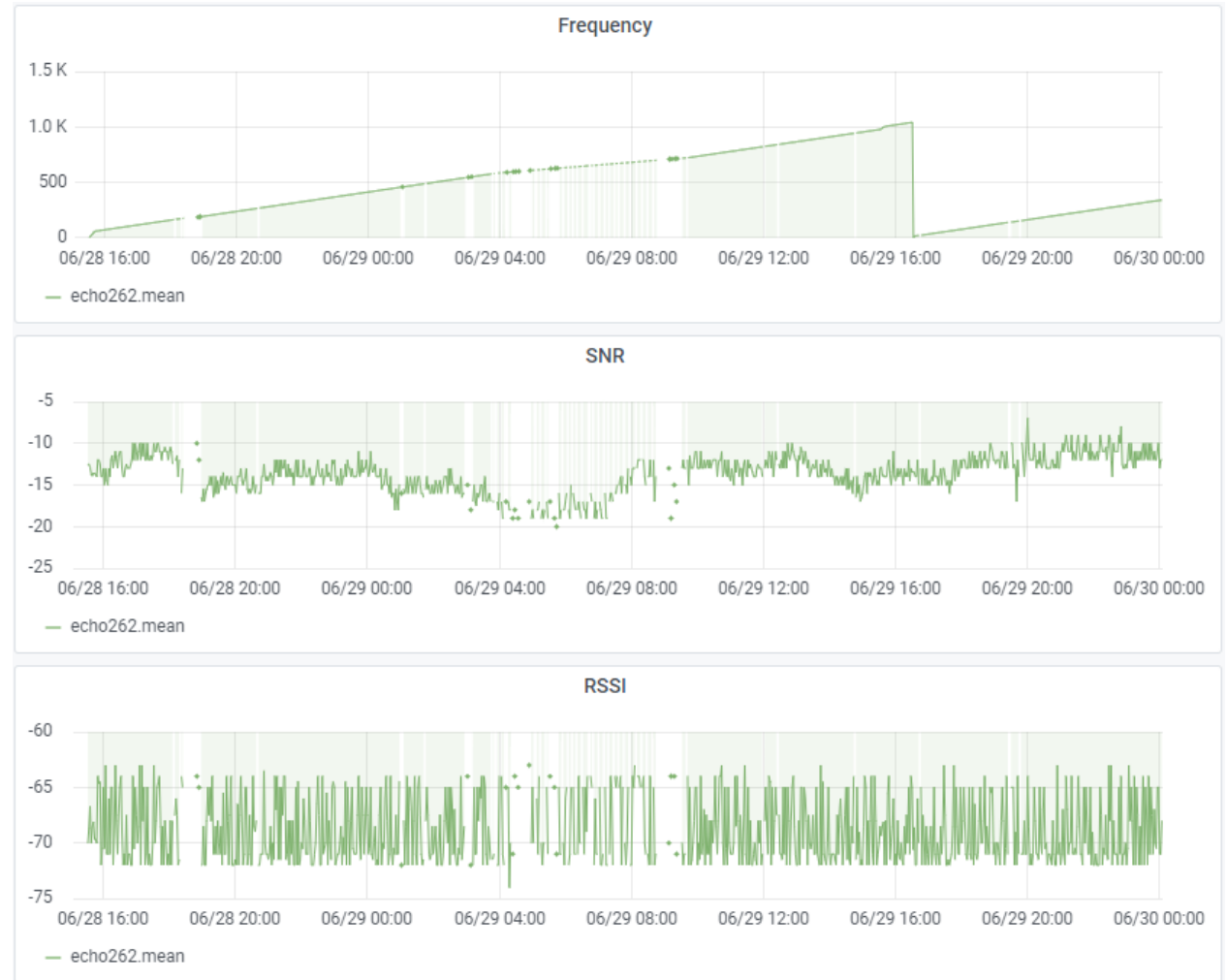
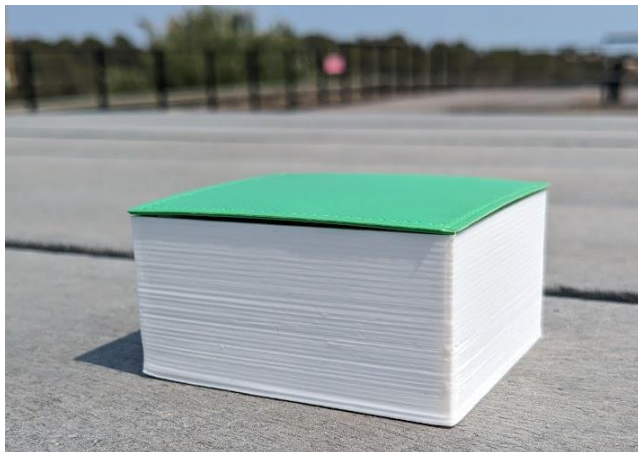

Conclusions

	Swarm	Kineis	Eutelsat	Lacuna	Astrocast	Echostar
Frequencies	VHF (144M) UHF (400M)	UHF (400M)	UHF(400M)/ ISM	ISM (868M) S-band (2G)	L-band (1.61G)	S-band (2G)
Constellation	120 -> 400	7 -> 27	4 -> 25	4 -> 150	18->80	GEO (EU &US) -> LEO (28)
Modulation	LoRa	Proprietary	Proprietary	LR-FHSS	Proprietary QPSK	LR-FHSS
Latency	>15mn	>15mn	>15mn	>15mn	>15mn	500ms
Downlink	Bi-directional	Bi-directional	Bi-directional	Broadcast	Bi-directional	Bi-directional
Chip/ Electronic	Proprietary module	STM32WL	Proprietary module	SX126X, LR11XX	Proprietary module	Proprietary module -> LR1120

- Future of IoT for remote area
 - Similar power consumption and RF power with terrestrial network
 - 200 byte/s, 50 byte per message, a message every day ...
- > Satellite fit perfectly with Edge Technology
- Choice is not easy

Perspectives for Laos

- Lacuna at 924MHz is already working over Laos, but almanach is not broadcasted
- Omnispace/ Lacuna in S-band would fit perfectly but we need a government authorization for licensing

- M. T. Nguyen, V. L. Tran, F. Ferrero and L. H. Trinh, "Low-power LoRaWAN Extender Using Multiple Relays: Design and Evaluation," 2022 International Conference on Advanced Technologies for Communications (ATC), Ha Noi, Vietnam, 2022, pp. 257-261, doi: 10.1109/ATC55345.2022.9942993.
- F. Ferrero and L. -H. Trinh, "Multi-band antenna system for IoT from Space applications," 2022 16th European Conference on Antennas and Propagation (EuCAP), Madrid, Spain, 2022, pp. 1-3, doi: 10.23919/EuCAP53622.2022.9769350.
- Trinh, L.H.; Truong, N.V.; Ferrero, F. Low Cost Circularly Polarized Antenna for IoT Space Applications. *Electronics* **2020**, *9*, 1564. <https://doi.org/10.3390/electronics9101564>
- M. T. Nguyen, L. H. Trinh and F. Ferrero, "Impact of Miniaturization on a UHF tri-fillar antenna for IoT communication from satellite," 2020 IEEE International Symposium on Antennas and Propagation and North American Radio Science Meeting, Montreal, QC, Canada, 2020, pp. 403-404, doi: 10.1109/IEEECONF35879.2020.9329452.